



RIVNUT[®]

The Original Blind Rivet Nut

BOLLHOFF

Authorized Distributor



(877)923-2900

A commitment to quality

Our facilities are certified to international ISO and TS standards, and we seek the highest level of quality throughout your experience.

A leader in assembly technology

We specialize in the joining of lightweight and dissimilar materials, and provide reliable and efficient installation tools.

Your partner for innovation

We design fastening solutions for broad markets from transportation, to construction, to electronics.

An international service provider

Operating in 21 countries enables us to serve global customers with local engineering, manufacturing, and quality support.

A state-of-the-art manufacturer

We utilize the latest manufacturing methods, combined with a well-trained, highly-skilled workforce.

CLICK ON THE PAGE NUMBER IN THE TABLE OF CONTENTS TO GO DIRECTLY TO THAT SECTION OF THIS CATALOG.
 TO RETURN TO THE TABLE OF CONTENTS FROM ANY PAGE, CLICK ON THE BLUE BAR AT THE BOTTOM OF ANY PAGE.

Contents

RIVNUT® – The Original 4

RIVNUT® – PLUSNUT® 12

RIVNUT® – PLUSNUT® Pre-Bulbed 13

RIVNUT® – RIVKLE® 14

RIVNUT® – TW 15

RIVNUT® – HRT 18

RIVNUT® – Special Designs 22

RIVNUT® Power Tools – P2005 and P2007 24

RIVNUT® Power Tools – P1007 and P3007 25

RIVNUT® Power Tools – EPK C and SAC310 26

RIVNUT® Power Tools – HSA 803 and C302 27

RIVNUT® Hand Tools – C1000, and C722/C845 28

Fastener/Tool Selection Guide 29

Engineering Data 30

Decimal Conversions 34

About us 35

All information provided in this catalog is intended as a guideline only. Böllhoff Inc. recommends customer testing of actual application components, fasteners and tools to verify the design and reliability of the customer's actual application.

RIVNUT® The Original

How the RIVNUT® works:

- Thread RIVNUT® onto the tool mandrel
- Place in the hole
- Pull the tool trigger and the tool mandrel retracts causing the unthreaded portion of the RIVNUT® to expand behind the parent material riveting itself in place.

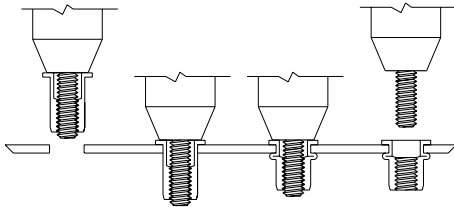

RIVNUT® - The Original Design and Assembly Advantages

- Installs blind in sheet metal, plastics and tubular materials.
- Can be used as a rivet to assemble two or more materials and as a nut for the attachment of a mating part with a screw.
- Installs into galvanized or pre-painted materials without damaging surface finishes.
- Installs mechanically without deforming the parent material.
- Installs before or after a finish is applied to the base material.
- Installs into material as thin as .020 (0.5mm) providing strong loadbearing threads.
- Installs at a rate of 20 pieces per minute with pneumatic power tools.
- Installs with inexpensive hand tools for field repair or consumer kit installation.
- Installs with semi-skilled labor with minimal training.
- Is ideal for automated assembly due to a balanced geometric shape.
- Installation is environmentally friendly and produces no harmful gasses, heat, dust or electromagnetic fields to affect workers.
- Installs into a wide range of material thicknesses due to a wide grip range tolerance.
- Meets Property class 5 and Metric class 8.8 mating screw proof loads.

**UNITED STATES PATENT OFFICE
2,149,199**

TUBULAR RIVET

“RIVNUT® - The Original blind installed internally threaded rivet, was invented (patent #2,149,199) in 1936 for the purpose of attaching a rubber aircraft wing de-icer extrusion to the leading edge of the wing. The RIVNUT® riveted the aluminum wing skin to the inner aluminum spar and then accepted a mating screw to attach the rubber de-icer.

The RIVNUT® fastener was given a military specification of MS27130 and an aerospace standard of NAS1329 and NAS1330. Use of the RIVNUT® expanded within the military and aerospace markets, and soon became popular in general industry because of its many design and assembly advantages.”

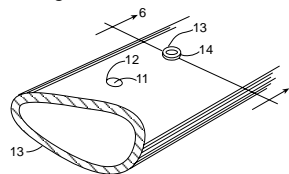

Fig. 5

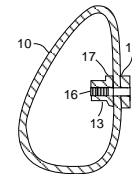

Fig. 6

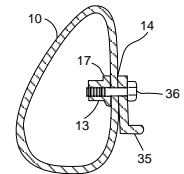
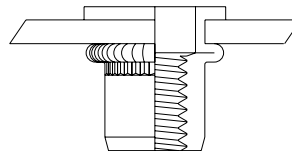
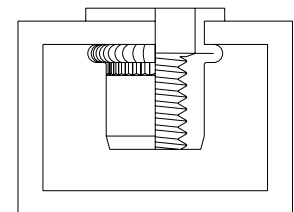

Fig. 7

sheet metals



tubing



riveting

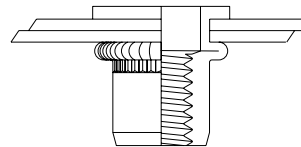

riveting

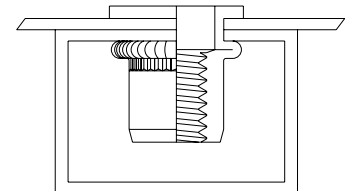

assembly

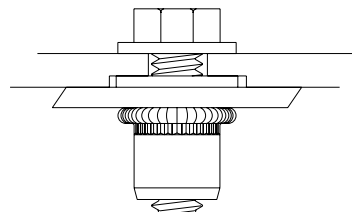

assembly

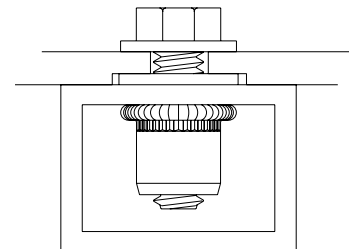

RIVNUT® Product Overview



The Original RIVNUT® (pages 6-11)

- Thick wall construction for ultimate tensile and push-out strength
- Flat head, countersink, and hex styles available
- Available in steel, stainless steel, aluminum and brass



RIVNUT® - PLUSNUT® (pages 12-13)

- Large backside flange diameter for high pull-out loads
- Slotted body for the widest available grip range
- Ideal for plastic and thin sheet applications
- Available in steel, stainless steel, aluminum and brass



RIVNUT® - RIVKLE® (page 14)

- European design for "true metric" hole sizes
- Wide variety of styles and thread sizes
- Available in steel, aluminum and stainless steel



RIVNUT® TW (pages 15-17)

- Thin wall construction
- Compatible with spin-spin and spin-pull tooling
- Low profile head and hex body available
- Available in steel and aluminum



RIVNUT® HRT (pages 18-21)

- High strength RIVNUT® fasteners
- Steel RIVNUT® fasteners compatible with Class 12.9 fasteners
- Aluminum RIVNUT® fasteners compatible with Class 8.8 fasteners

Special Designs (pages 22-23)

Power Tools (pages 24-27)

Hand Tools (page 28)

RIVNUT® Flat Head Round Body Open End (inch)

The RIVNUT® – Flat Head Round Body has been designed for use in round drilled or punched holes. It features a thick wall construction for high push out loads and riveting strength. The RIVNUT® is designed for use with inch Property class 5 mating hardware. A grip ID mark is included on the head of the fastener for grip range identification.

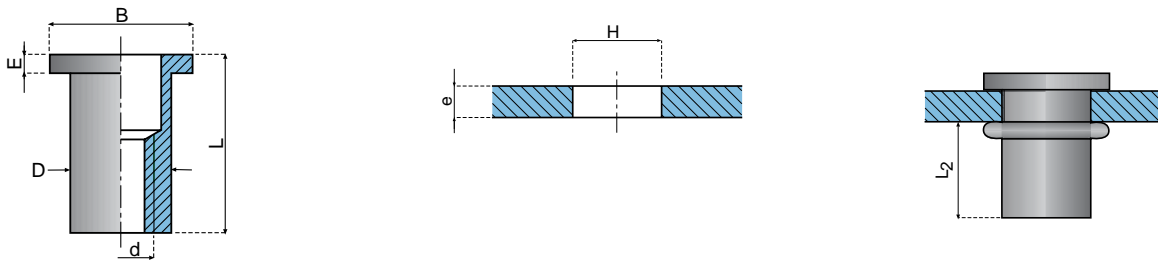

Class 3B threads
Steel: C1010

d Thread Size	e Grip Range	H Hole Size		D Body Diameter	E Head Height	B Head Diameter	L Overall Length	L ₂ Installed Length	Grip ID Mark	Product Code
		Min.	Max.							
6-32	0.010-0.075	0.190	0.193	0.189	0.032	0.325	0.470	0.300	1 RAD	S6-75
6-32	0.075-0.120	0.190	0.193	0.189	0.032	0.325	0.532	0.315	3 RAD	S6-120
8-32	0.010-0.075	0.222	0.226	0.221	0.032	0.357	0.470	0.300	1 RAD	S8-75
8-32	0.075-0.120	0.222	0.226	0.221	0.032	0.357	0.532	0.315	3 RAD	S8-120
8-32	0.120-0.160	0.222	0.226	0.221	0.032	0.357	0.532	0.270	5 RAD	S8-160
10-32	0.010-0.080	0.251	0.256	0.250	0.038	0.406	0.569	0.380		S10-80
10-32	0.080-0.130	0.251	0.256	0.250	0.038	0.406	0.632	0.390	1 RAD	S10-130
10-32	0.130-0.180	0.251	0.256	0.250	0.038	0.406	0.679	0.390	2 RAD	S10-180
10-32	0.180-0.230	0.251	0.256	0.250	0.038	0.406	0.741	0.395	3 RAD	S10-230
1/4-20	0.020-0.080	0.333	0.338	0.332	0.058	0.475	0.683	0.450		S25-80
1/4-20	0.080-0.140	0.333	0.338	0.332	0.058	0.475	0.745	0.450	1 RAD	S25-140
1/4-20	0.140-0.200	0.333	0.338	0.332	0.058	0.475	0.808	0.450	2 RAD	S25-200
1/4-20	0.200-0.260	0.333	0.338	0.332	0.058	0.475	0.870	0.445	3 RAD	S25-260
5/16-18	0.030-0.125	0.414	0.423	0.413	0.062	0.665	0.812	0.505		S31-125
5/16-18	0.125-0.200	0.414	0.423	0.413	0.062	0.665	0.937	0.555	1 RAD	S31-200
5/16-18	0.200-0.275	0.414	0.423	0.413	0.062	0.665	0.999	0.540	2 RAD	S31-275
5/16-18	0.275-0.350	0.414	0.423	0.413	0.062	0.665	1.094	0.560	3 RAD	S31-350
3/8-16	0.030-0.115	0.491	0.500	0.490	0.088	0.781	0.932	0.585		S37-115
3/8-16	0.115-0.200	0.491	0.500	0.490	0.088	0.781	1.026	0.595	1 RAD	S37-200
3/8-16	0.200-0.285	0.491	0.500	0.490	0.088	0.781	1.119	0.605	2 RAD	S37-285
3/8-16	0.285-0.370	0.491	0.500	0.490	0.088	0.781	1.213	0.615	3 RAD	S37-370
1/2-13	0.050-0.150	0.626	0.635	0.625	0.085	0.906	0.991	0.605		S50-150
1/2-13	0.150-0.250	0.626	0.635	0.625	0.085	0.906	1.116	0.630	1 RAD	S50-250
1/2-13	0.250-0.350	0.626	0.635	0.625	0.085	0.906	1.226	0.640	2 RAD	S50-350
1/2-13	0.350-0.450	0.626	0.635	0.625	0.085	0.906	1.335	0.650	3 RAD	S50-450

Note 1: The product on this page is made from Steel ("S" prefix in product code). It is also available in Stainless Steel ("SS" for the prefix), Aluminum ("A" for the prefix), or Alloy Steel ("CH" for the prefix).

Note 2: Other design variations are available upon request.

RIVNUT® Flat Head Round Body Open End (metric)

The RIVNUT® – Flat Head Round Body has been designed for use in round drilled or punched holes. It features a thick wall construction for high push out loads and riveting strength. The RIVNUT® is designed for use with metric Class 8.8 mating hardware. A grip ID mark is included on the head of the fastener for grip range identification.

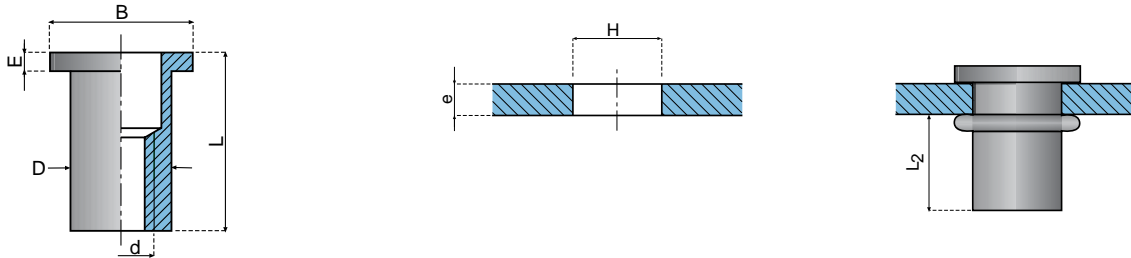

Class 6H threads
Steel: C1010

d Thread Size	e Grip Range	H Hole Size		D Body Diameter	E Head Height	B Head Diameter	L Overall Length	L ₂ Installed Length	Grip ID Mark	Product Code
		Min.	Max.							
M4x0.7	0.25-2.00	5.62	5.74	5.62	0.81	9.0	11.8	7.1		SM4-2.0
M4x0.7	2.00-3.00	5.62	5.74	5.62	0.81	9.0	12.8	7.1	1 RAD	SM4-3.0
M4x0.7	3.00-4.00	5.62	5.74	5.62	0.81	9.0	13.8	7.1	2 RAD	SM4-4.0
M5x0.8	0.25-2.00	7.20	7.30	7.14	1.22	11.2	15.7	10.1		SM5-2.0
M5x0.8	2.00-3.50	7.20	7.30	7.14	1.22	11.2	17.2	10.1	1 RAD	SM5-3.5
M5x0.8	3.50-5.00	7.20	7.30	7.14	1.22	11.2	18.7	10.1	2 RAD	SM5-5.0
M5x0.8	5.00-6.50	7.20	7.30	7.14	1.22	11.2	20.2	10.1	3 RAD	SM5-6.5
M6x1.0	0.75-2.00	8.50	8.60	8.44	1.47	13.4	17.0	10.6		SM6-2.0
M6x1.0	2.00-3.50	8.50	8.60	8.44	1.47	13.4	18.5	10.6	1 RAD	SM6-3.5
M6x1.0	3.50-5.00	8.50	8.60	8.44	1.47	13.4	20.0	10.6	2 RAD	SM6-5.0
M6x1.0	5.00-6.50	8.50	8.60	8.44	1.47	13.4	21.5	10.6	3 RAD	SM6-6.5
M8x1.25	1.00-3.00	10.50	10.70	10.49	1.57	16.7	19.6	11.8		SM8-3.0
M8x1.25	3.00-5.00	10.50	10.70	10.49	1.57	16.7	21.6	11.8	1 RAD	SM8-5.0
M8x1.25	5.00-7.00	10.50	10.70	10.49	1.57	16.7	23.6	11.8	2 RAD	SM8-7.0
M8x1.25	7.00-9.00	10.50	10.70	10.49	1.57	16.7	25.6	11.8	3 RAD	SM8-9.0
M10x1.50	1.00-3.00	12.50	12.70	12.45	2.23	19.5	22.2	13.2		SM10-3.0
M10x1.50	3.00-5.50	12.50	12.70	12.45	2.23	19.5	24.7	13.2	1 RAD	SM10-5.5
M10x1.50	5.50-8.00	12.50	12.70	12.45	2.23	19.5	27.2	13.2	2 RAD	SM10-8.0
M10x1.50	8.00-10.50	12.50	12.70	12.45	2.23	19.5	29.7	13.2	3 RAD	SM10-10.5
M12x1.75	1.00-3.00	15.50	15.70	15.47	2.23	22.8	26.2	16.4		SM12-3.0
M12x1.75	3.00-5.50	15.50	15.70	15.47	2.23	22.8	28.7	16.4	1 RAD	SM12-5.5
M12x1.75	5.50-8.00	15.50	15.70	15.47	2.23	22.8	31.2	16.4	2 RAD	SM12-8.0
M12x1.75	8.00-10.50	15.50	15.70	15.47	2.23	22.8	33.7	16.4	3 RAD	SM12-10.5

Note 1: The product on this page is made from Steel ("S" prefix in product code). It is also available in Stainless Steel ("SS" for the prefix), Aluminum ("A" for the prefix), or Alloy Steel ("CH" for the prefix).

Note 2: Other design variations are available upon request.

RIVNUT® Flat Head Round Body Closed End

The RIVNUT® – Flat Head Round Body Closed End has been designed for use in round drilled or punched holes. It features a thick wall construction for riveting strength and a closed end to seal the threads. The RIVNUT® is designed for use with inch Property class 5 hardware. A grip ID mark is included on the head of the fastener for grip range identification.

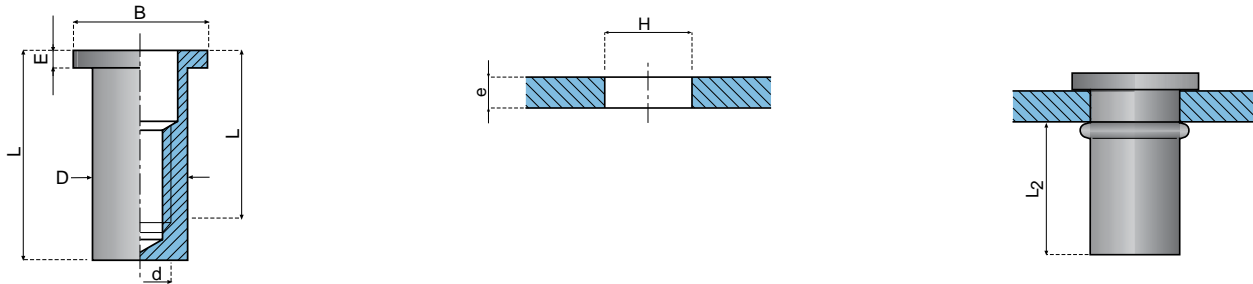

Class 3B threads
Steel: C1010

d Thread Size	e Grip Range	H Hole Size		D Body Diameter	E Head Height	B Head Diameter	L Overall Length	L ₂ Installed Length	Grip ID Mark	Product Code
		Min.	Max.							
6-32	0.010-0.075	0.190	0.193	0.189	0.032	0.325	0.657	0.490	1 RAD	S6B75
6-32	0.075-0.120	0.190	0.193	0.189	0.032	0.325	0.657	0.440	2 RAD	S6B120
8-32	0.010-0.075	0.222	0.226	0.221	0.032	0.357	0.657	0.490	1 RAD	S8B75
8-32	0.075-0.120	0.222	0.226	0.221	0.032	0.357	0.657	0.440	3 RAD	S8B120
8-32	0.120-0.160	0.222	0.226	0.221	0.032	0.357	0.782	0.520	5 RAD	S8B160
10-32	0.010-0.080	0.251	0.256	0.250	0.038	0.406	0.819	0.630		S10B80
10-32	0.080-0.130	0.251	0.256	0.250	0.038	0.406	0.881	0.640	1 RAD	S10B130
10-32	0.130-0.180	0.251	0.256	0.250	0.038	0.406	0.929	0.640	2 RAD	S10B180
10-32	0.180-0.230	0.251	0.256	0.250	0.038	0.406	0.991	0.645	3 RAD	S10B230
1/4-20	0.020-0.080	0.333	0.338	0.332	0.058	0.475	0.995	0.760		S25B80
1/4-20	0.080-0.140	0.333	0.338	0.332	0.058	0.475	1.058	0.760	1 RAD	S25B140
1/4-20	0.140-0.200	0.333	0.338	0.332	0.058	0.475	1.120	0.760	2 RAD	S25B200
1/4-20	0.200-0.260	0.333	0.338	0.332	0.058	0.475	1.183	0.755	3 RAD	S25B260
5/16-18	0.030-0.125	0.414	0.423	0.413	0.062	0.665	1.249	0.940		S31B125
5/16-18	0.125-0.200	0.414	0.423	0.413	0.062	0.665	1.343	0.960	1 RAD	S31B200
5/16-18	0.200-0.275	0.414	0.423	0.413	0.062	0.665	1.405	0.950	2 RAD	S31B275
5/16-18	0.275-0.350	0.414	0.423	0.413	0.062	0.665	1.499	0.965	3 RAD	S31B350
3/8-16	0.030-0.115	0.491	0.500	0.490	0.088	0.781	1.369	1.020		S37B115
3/8-16	0.115-0.200	0.491	0.500	0.490	0.088	0.781	1.463	1.030	1 RAD	S37B200
3/8-16	0.200-0.285	0.491	0.500	0.490	0.088	0.781	1.556	1.040	2 RAD	S37B285
3/8-16	0.285-0.370	0.491	0.500	0.490	0.088	0.781	1.650	1.050	3 RAD	S37B370
1/2-13	0.050-0.150	0.626	0.635	0.625	0.085	0.906	1.413	1.030		S50B150
1/2-13	0.150-0.250	0.626	0.635	0.625	0.085	0.906	1.538	1.055	1 RAD	S50B250
1/2-13	0.250-0.350	0.626	0.635	0.625	0.085	0.906	1.647	1.060	2 RAD	S50B350
1/2-13	0.350-0.450	0.626	0.635	0.625	0.085	0.906	1.756	1.070	3 RAD	S50B450

Note 1: The product on this page is made from Steel ("S" prefix in product code). It is also available in Stainless Steel ("SS" for the prefix), Aluminum ("A" for the prefix), or Alloy Steel ("CH" for the prefix).

Note 2: Other design variations are available upon request.

RIVNUT® Countersunk Head Round Body

The RIVNUT® – Countersunk Head Round Body has been designed for use in round drilled or punched holes. It features a thick wall construction for high push out and riveting strength. It also includes a 100° countersunk head for applications requiring a completely flush installation. A grip ID mark is included on the head of the fastener for grip range identification.

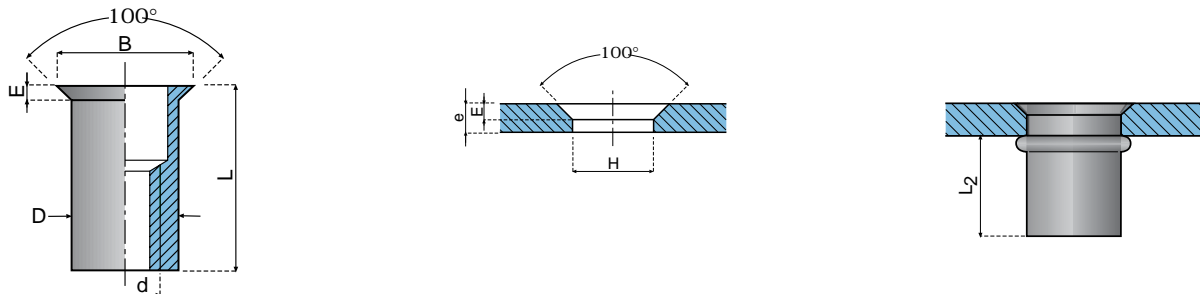

Class 3B threads
Steel: C1010

d Thread Size	e Grip Range	H Hole Size		D Body Diameter	E Head Height	B Head Diameter	L Overall Length	L ₂ Installed Length	Grip ID Mark	Product Code
		Min.	Max.							
6-32	0.065-0.106	0.190	0.193	0.189	0.063	0.323	0.500	0.325		S6-106
6-32	0.106-0.161	0.190	0.193	0.189	0.063	0.323	0.500	0.280	2 RAD	S6-161
8-32	0.065-0.106	0.222	0.226	0.221	0.063	0.355	0.500	0.325		S8-106
8-32	0.106-0.161	0.222	0.226	0.221	0.063	0.355	0.500	0.280	2 RAD	S8-161
8-32	0.161-0.201	0.222	0.226	0.221	0.063	0.355	0.562	0.290	4 RAD	S8-201
10-32	0.065-0.116	0.251	0.256	0.250	0.065	0.391	0.578	0.395		S10-116
10-32	0.116-0.166	0.251	0.256	0.250	0.065	0.391	0.625	0.385	1 RAD	S10-166
10-32	0.166-0.216	0.251	0.256	0.250	0.065	0.391	0.687	0.400	2 RAD	S10-216
10-32	0.216-0.266	0.251	0.256	0.250	0.065	0.391	0.734	0.390	3 RAD	S10-266
1/4-20	0.089-0.151	0.333	0.338	0.332	0.089	0.529	0.687	0.440		S25-151
1/4-20	0.151-0.211	0.333	0.338	0.332	0.089	0.529	0.750	0.440	1 RAD	S25-211
1/4-20	0.211-0.271	0.333	0.338	0.332	0.089	0.529	0.812	0.440	2 RAD	S25-271
1/4-20	0.271-0.331	0.333	0.338	0.332	0.089	0.529	0.875	0.435	3 RAD	S25-331
5/16-18	0.106-0.181	0.414	0.423	0.413	0.104	0.656	0.844	0.540		S31-181
5/16-18	0.181-0.256	0.414	0.423	0.413	0.104	0.656	0.937	0.560	1 RAD	S31-256
5/16-18	0.256-0.331	0.414	0.423	0.413	0.104	0.656	1.000	0.550	2 RAD	S31-331
5/16-18	0.331-0.406	0.414	0.423	0.413	0.104	0.656	1.093	0.565	3 RAD	S31-406
3/8-16	0.125-0.211	0.491	0.500	0.490	0.124	0.770	0.938	0.580		S37-211
3/8-16	0.211-0.296	0.491	0.500	0.490	0.124	0.770	1.031	0.590	1 RAD	S37-296
3/8-16	0.296-0.381	0.491	0.500	0.490	0.124	0.770	1.125	0.600	2 RAD	S37-381
3/8-16	0.381-0.466	0.491	0.500	0.490	0.124	0.770	1.219	0.615	3 RAD	S37-466
1/2-13	0.125-0.226	0.626	0.635	0.625	0.124	0.906	0.984	0.610		S50-226
1/2-13	0.226-0.326	0.626	0.635	0.625	0.124	0.906	1.094	0.620	1 RAD	S50-326
1/2-13	0.326-0.426	0.626	0.635	0.625	0.124	0.906	1.218	0.640	2 RAD	S50-426
1/2-13	0.426-0.526	0.626	0.635	0.625	0.124	0.906	1.312	0.635	3 RAD	S50-526

Note 1: The product on this page is made from Steel ("S" prefix in product code). It is also available in Stainless Steel ("SS" for the prefix), Aluminum ("A" for the prefix), or Alloy Steel ("CH" for the prefix).

Note 2: Other design variations are available upon request.

RIVNUT® Flat Head Hex Body (inch)

The RIVNUT® – Flat Head Hex Body is provided in both a standard and heavy hex design. The heavy hex design features a larger body diameter that results in increased thread strength and torque capability. The hex body design provides the ultimate in spin-out resistance when used in a hex hole. The RIVNUT® is designed for use with Property class 5 mating hardware. A grip ID mark is included on the head of the fastener for grip range identification.

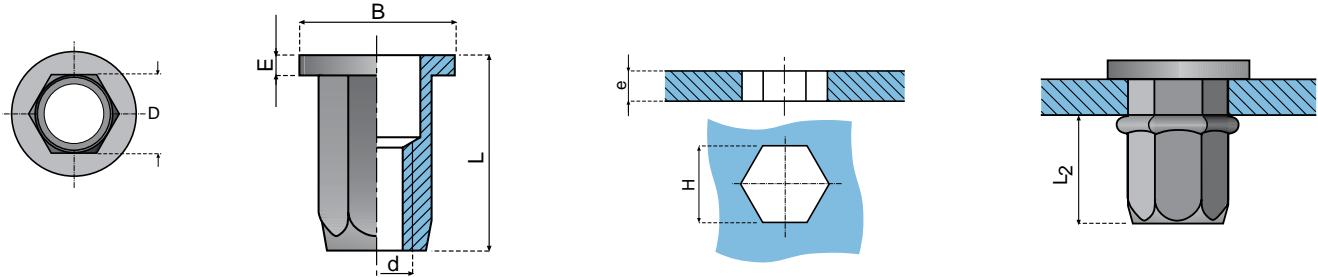

Class 3B threads
Steel: C1010

d	e	H		D	E	B	L	L ₂	Grip ID Mark	Product Code
		Min.	Max.							
Thread Size	Grip Range	Hole Size		Across Flats	Head Height	Head Diameter	Overall Length	Installed Length		
STANDARD HEX										
10-32	0.010-0.085	0.224	0.229	0.223	0.043	0.344	0.387	0.200		S10H85
10-32	0.085-0.135	0.224	0.229	0.223	0.043	0.344	0.449	0.210	1 RAD	S10H135
1/4-20	0.020-0.085	0.297	0.302	0.296	0.043	0.437	0.449	0.245		S25H85
1/4-20	0.085-0.145	0.297	0.302	0.296	0.043	0.437	0.512	0.250	1 RAD	S25H145
5/16-18	0.030-0.105	0.369	0.374	0.368	0.048	0.562	0.610	0.375		S31H105
5/16-18	0.105-0.175	0.369	0.374	0.368	0.048	0.562	0.688	0.380	1 RAD	S31H175
3/8-16	0.030-0.115	0.438	0.443	0.437	0.058	0.656	0.683	0.400		S37H115
3/8-16	0.115-0.205	0.438	0.443	0.437	0.058	0.656	0.776	0.405	1 RAD	S37H205
HEAVY HEX										
1/4-20	0.020-0.080	0.313	0.318	0.312	0.058	0.469	0.558	0.340		S25H80
1/4-20	0.080-0.150	0.313	0.318	0.312	0.058	0.469	0.636	0.345	1 RAD	S25H150
5/16-18	0.020-0.100	0.398	0.403	0.397	0.062	0.594	0.687	0.405		S31H100
5/16-18	0.100-0.180	0.398	0.403	0.397	0.062	0.594	0.765	0.405	1 RAD	S31H180
3/8-16	0.020-0.125	0.469	0.478	0.468	0.088	0.688	0.791	0.450		S37H125
3/8-16	0.125-0.230	0.469	0.478	0.468	0.088	0.688	0.900	0.450	1 RAD	S37H230

Note 1: The product on this page is made from Steel (“S” prefix in product code). It is also available in Stainless Steel (“SS” for the prefix), Aluminum (“A” for the prefix), or Alloy Steel (“CH” for the prefix).

Note 2: Other design variations are available upon request.

RIVNUT® Flat Head Hex Body (metric)

The RIVNUT® – Flat Head Hex Body provides the ultimate in spin-out resistance when used in a hex hole. The RIVNUT® is designed for use with metric Class 8.8 mating hardware. A grip ID mark is included on the head of the fastener for grip range identification.

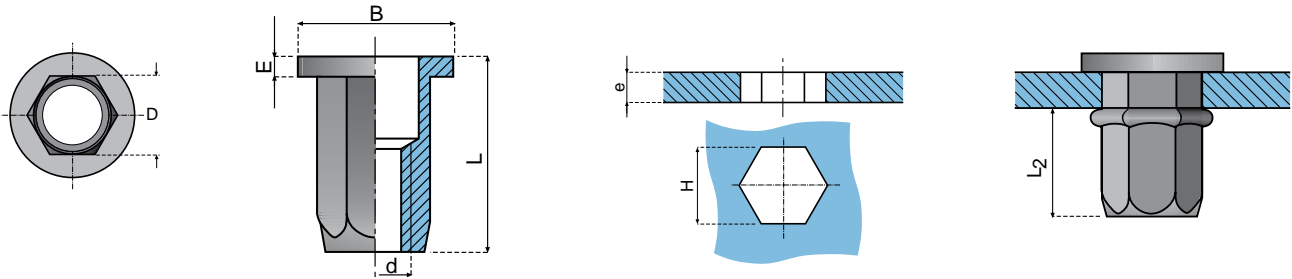

Class 6H threads
Steel: C1010

d Thread Size	e Grip Range	H Hole Size		D Across Flats	E Head Height	B Head Diameter	L Overall Length	L ₂ Installed Length	Grip ID Mark	Product Code
		Min.	Max.							
STANDARD HEX										
M5x0.8	0.50-2.15	6.36	6.50	6.35	1.09	9.5	11.4	6.7		SM5H2.15
M5x0.8	2.15-3.55	6.36	6.50	6.35	1.09	9.5	13.0	6.7	1 RAD	SM5H3.55
M6x1.0	0.50-2.15	7.54	7.66	7.52	1.09	11.1	11.4	6.2		SM6H2.15
M6x1.0	2.15-3.65	7.54	7.66	7.52	1.09	11.1	13.0	6.2	1 RAD	SM6H3.65
M8x1.25	0.50-2.55	10.11	10.23	10.08	1.57	15.1	17.4	10.4		SM8H2.55
M8x1.25	2.55-4.55	10.11	10.23	10.08	1.57	15.1	19.4	10.4	1 RAD	SM8H4.55
M10x1.50	0.75-2.95	11.91	12.14	11.89	1.57	17.5	17.5	13.1		SM10H2.95
M10x1.50	2.95-5.20	11.91	12.14	11.89	1.57	17.5	19.8	13.1	1 RAD	SM10H5.20

Note 1: The product on this page is made from Steel (“S” prefix in product code). It is also available in Stainless Steel (“SS” for the prefix), Aluminum (“A” for the prefix), or Alloy Steel (“CH” for the prefix).

Note 2: Other design variations are available upon request.

RIVNUT® PLUSNUT®

The PLUSNUT® has been designed to provide the ultimate pull out strength in thin sheet metals and plastic. Its slotted body splits into four legs providing a wide load-bearing surface on the backside of the parent material. The PLUSNUT® also features the widest grip range of any blind threaded nut. A grip ID mark is included on the head of the fastener for grip range identification.

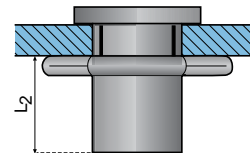
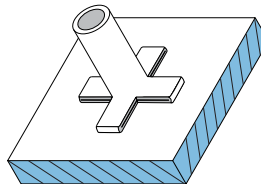
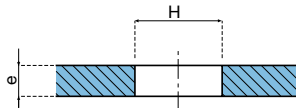
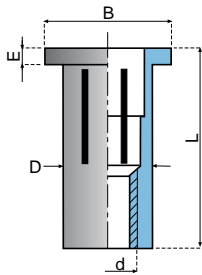

Class 2B or Metric Class 6H threads
Steel: C1010

d Thread Size	e Grip Range	H Hole Size		D Body Diameter	E Head Height	B Head Diameter	L Overall Length	L ₂ Installed Length	Grip ID Mark	Product Code
		Min.	Max.							

All Dimensions Shown In Inches

6-32	0.020-0.150	0.209	0.214	0.208	0.032	0.438	0.688	0.335		S6P150
6-32	0.150-0.270	0.209	0.214	0.208	0.032	0.438	0.797	0.335	1 RAD	S6P270
8-32	0.020-0.150	0.242	0.247	0.241	0.038	0.438	0.694	0.340		S8P150
8-32	0.150-0.270	0.242	0.247	0.241	0.038	0.438	0.819	0.340	1 RAD	S8P270
10-32	0.020-0.175	0.273	0.278	0.272	0.038	0.500	0.819	0.425		S10P175
10-32	0.175-0.320	0.273	0.278	0.272	0.038	0.500	0.959	0.425	1 RAD	S10P320
1/4-20	0.020-0.280	0.347	0.352	0.346	0.058	0.625	1.058	0.505		S25P280
1/4-20	0.280-0.500	0.347	0.352	0.346	0.058	0.625	1.292	0.505	1 RAD	S25P500
5/16-18	0.020-0.280	0.438	0.443	0.437	0.062	0.750	1.203	0.570		S31P280
5/16-18	0.280-0.500	0.438	0.443	0.437	0.062	0.750	1.437	0.570	1 RAD	S31P500
3/8-16	0.020-0.280	0.515	0.522	0.514	0.088	0.875	1.306	0.605		S37P280
3/8-16	0.280-0.500	0.515	0.522	0.514	0.088	0.875	1.525	0.605	1 RAD	S37P500

All Dimensions Shown In Millimeters

M4x0.7	0.50-3.80	6.13	6.25	6.12	0.96	11.1	17.6	8.6		SM4P3.80
M4x0.7	3.80-6.85	6.13	6.25	6.12	0.96	11.1	20.8	8.6	1 RAD	SM4P6.85
M5x0.8	0.50-4.45	7.48	7.62	7.47	0.96	12.7	22.0	9.9		SM5P4.45
M5x0.8	4.45-8.10	7.48	7.62	7.47	0.96	12.7	24.8	9.9	1 RAD	SM5P8.10
M6x1.0	0.50-7.10	8.80	8.93	8.79	1.50	15.9	26.9	12.8		SM6P7.10
M6x1.0	7.10-12.70	8.80	8.93	8.79	1.50	15.9	32.8	12.8	1 RAD	SM6P12.70
M8x1.25	0.50-7.10	11.11	11.50	11.10	1.57	19.0	30.5	14.5		SM8P7.10
M8x1.25	7.10-12.70	11.11	11.50	11.10	1.57	19.0	36.5	14.5	1 RAD	SM8P12.70
M10x1.50	0.50-7.10	13.07	13.26	13.06	2.24	22.2	33.2	15.8		SM10P7.10
M10x1.50	7.10-12.70	13.07	13.26	13.06	2.24	22.2	38.7	15.8	1 RAD	SM10P12.70

Note 1: The product on this page is made from Steel ("S" prefix in product code). It is also available in Stainless Steel ("SS" for the prefix) or Aluminum ("A" for the prefix).

Note 2: Countersunk head, finishes or design variations are available upon request.

RIVNUT® PLUSNUT® Pre-Bulbed

The PLUSNUT® Pre-Bulbed has been designed to be installed using torque controlled hand or power tools. A simple torque hand tool (shown on page 28) can be packaged with this fastener for customer installation. Use of the C302 power tool (shown on page 27) can install this fastener in variable thickness plastic materials such as those produced by rotational or blow molding. A grip ID mark is included on the head of the fastener for grip range identification.

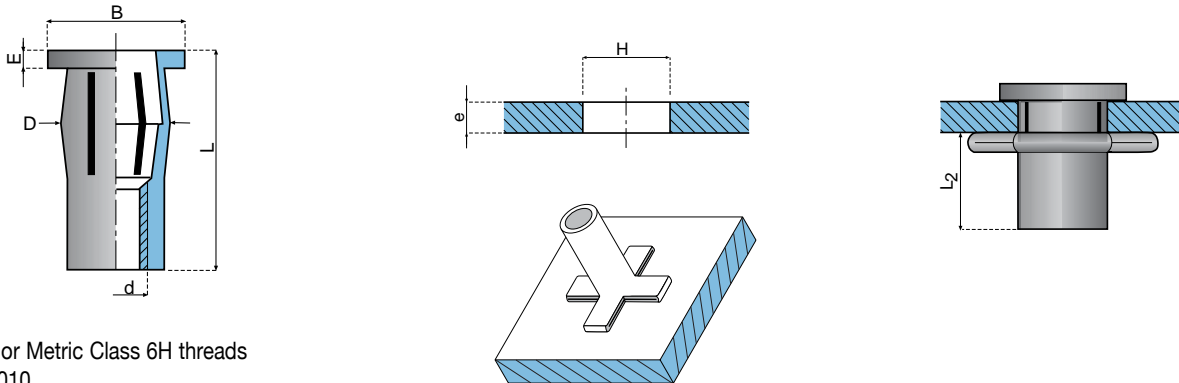

Class 2B or Metric Class 6H threads
Steel: C1010

d Thread Size	e Grip Range	H Hole Size		D Body Diameter	E Head Height	B Head Diameter	L Overall Length	L ₂ Installed Length	Grip ID Mark	Product Code
		Min.	Max.							

All Dimensions Shown In Inches

10-32	0.020-0.175	0.312	0.317	0.310	0.038	0.500	0.80	0.425		S10PB175
10-32	0.175-0.320	0.312	0.317	0.310	0.038	0.500	0.94	0.425	1 RAD	S10PB320
1/4-20	0.020-0.280	0.386	0.391	0.384	0.058	0.625	1.03	0.505		S25PB280
1/4-20	0.280-0.500	0.386	0.391	0.384	0.058	0.625	1.26	0.505	1 RAD	S25PB500
5/16-18	0.020-0.280	0.484	0.489	0.482	0.062	0.750	1.18	0.570		S31PB280
5/16-18	0.280-0.500	0.484	0.489	0.482	0.062	0.750	1.41	0.570	1 RAD	S31PB500
3/8-16	0.020-0.280	0.562	0.569	0.560	0.088	0.875	1.27	0.605		S37PB280
3/8-16	0.280-0.500	0.562	0.569	0.560	0.088	0.875	1.49	0.605	1 RAD	S37PB500

All Dimensions Shown In Millimeters

M6x1.0	0.50-7.10	9.80	9.93	9.76	1.50	15.9	26.2	12.8		SM6PB7.10
M6x1.0	7.10-12.70	9.80	9.93	9.76	1.50	15.9	32.0	12.8	1 RAD	SM6PB12.70
M8x1.25	0.50-7.10	12.29	12.42	12.25	1.57	19.0	30.0	14.5		SM8PB7.10
M8x1.25	7.10-12.70	12.29	12.42	12.25	1.57	19.0	35.8	14.5	1 RAD	SM8PB12.70
M10x1.50	0.50-7.10	14.27	14.45	14.23	2.24	22.2	32.3	15.4		SM10PB7.10
M10x1.50	7.10-12.70	14.27	14.45	14.23	2.24	22.2	37.8	15.4	1 RAD	SM10PB12.70

Note 1: The product on this page is made from Steel ("S" prefix in product code) with Cadmium plating. It is also available in Stainless Steel ("SS" for the prefix) or Aluminum ("A" for the prefix).

Note 2: Countersunk head, finishes or design variations are available upon request.

RIVNUT® RIVKLE®

The RIVKLE® product line features the standard European design for “true metric” hole sizes. As a global company, we are able to offer a wide variety of styles and thread sizes. We are also able to offer the RIVKLE® line in a number of materials including steel, aluminum and stainless steel.

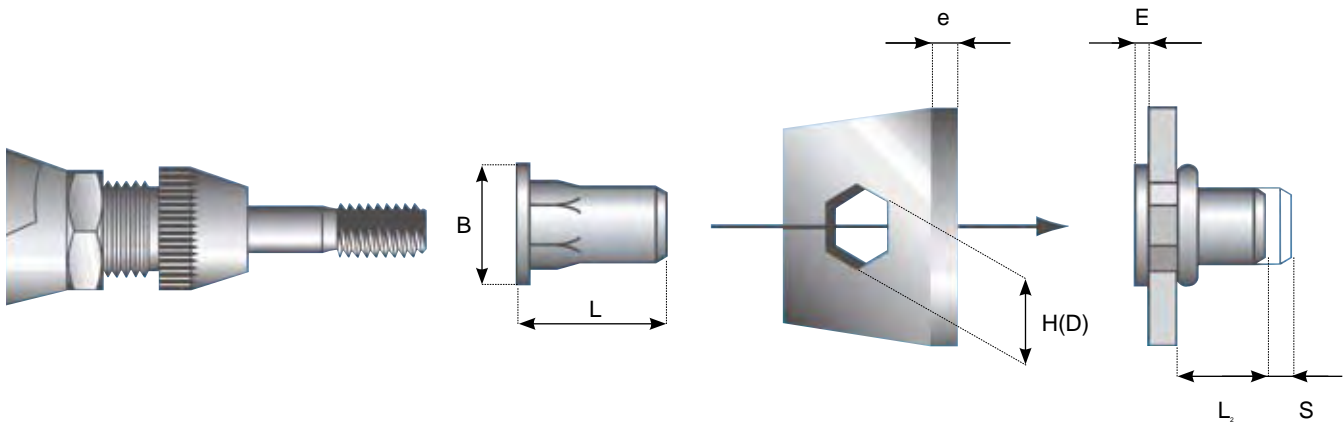

RIVKLE®

Type	Thread d	Material-Thickness e	Hole-Round (D) Hexagonal (H) Tol. +0,1	Ø Head B	Projection After Setting E max	Setting Stroke S	Total Length L	Blind side projection after setting L ₂	Product Code
	M4	0.5 – 3.0	6	9	1.0	S = 4.5-e	11.3	5.8	2330 704 0230
	M5	0.5 – 3.0	7	10	1.0	S = 4.7-e	13.0	7.3	2330 705 0230
	M6	0.5 – 3.0	9	13	1.5	S = 5.0-e	14.5	8.0	2330 706 0230
	M6	3.0 – 5.5	9	13	1.5	S = 7.5-e	17.2	8.2	2330 706 0255
	M8	0.5 – 3.0	11	16	1.5	S = 5.5-e	18.0	11.0	2330 708 0230
	M8	3.0 – 5.5	11	16	1.5	S = 8.1-e	20.7	11.1	2330 708 0255
	M10	0.7 – 3.5	13	19	2.0	S = 6.1-e	22.0	13.9	2330 710 0235
	M4	0.5 – 3.0	6	9	1.0	S = 4.5-e	11.3	5.8	2334 104 0230
	M5	0.5 – 3.0	7	10	1.0	S = 4.7-e	13.0	7.3	2334 105 0230
	M6	0.5 – 3.0	9	13	1.5	S = 5.0-e	14.5	8.0	2334 106 0230
	M8	0.5 – 3.0	11	16	1.5	S = 5.3-e	18.0	11.2	2334 108 0230
	M4	0.5 – 3.0	6	6.7	0.3	S = 4.9-e	11.0	5.8	3436 704 0230
	M5	0.5 – 3.0	7	8.0	0.3	S = 5.3-e	13.0	7.4	3436 705 0230
	M6	0.5 – 3.0	9	10.0	0.4	S = 5.1-e	14.0	8.5	3436 706 0230
	M8	0.5 – 3.0	11	12.0	0.4	S = 6.0-e	17.5	11.1	3436 708 0230
	M10	0.7 – 3.5	13	14.0	0.5	S = 6.5-e	21.0	14.0	3436 710 0235
	M4	0.5 – 3.0	6	7.5	0.3	S = 4.7-e	11.0	6.0	3434 104 0230
	M5	0.5 – 3.0	7	8.7	0.3	S = 5.2-e	13.0	7.5	3434 105 0230
	M6	0.5 – 3.0	9	10.9	0.4	S = 5.3-e	14.0	8.3	3434 106 0230
	M8	0.5 – 3.0	11	13.3	0.4	S = 5.8-e	17.5	11.3	3434 108 0230

Dimensions in mm

RIVNUT® TW Standard Head

The TW (thin wall) line is designed as a lower cost alternative for applications with reduced load requirements, and with a wider grip range. The Böllhoff TW line is compatible with both spin-spin and spin-pull tooling. Our offering includes the standard head, low profile head and half hex variety.

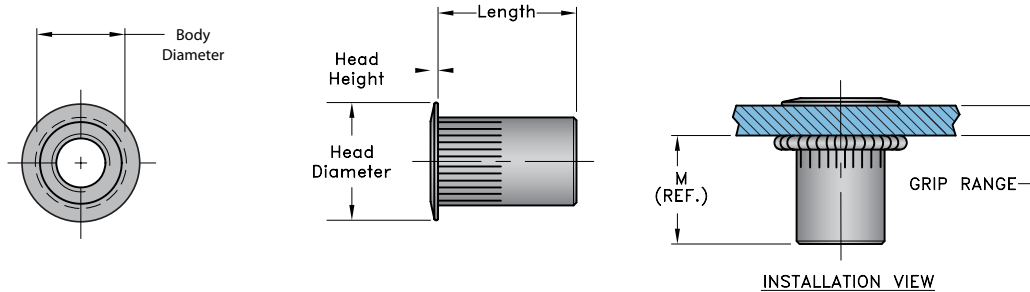

Class 2B or Metric Class 6H threads
Steel: C1010

Unified	Thread size	Grip Range	Hole Size min max	Body Diameter	Head Height	Head Diameter	Overall Length	Installed Length	Product Code
"L" Series	8-32 UNC	.020 - .080	.2656-.2716	0.265	0.030	0.390	0.420	0.305	BRLS-832-80
	8-32 UNC	.080 - .130	.2656-.2716	0.265	0.030	0.390	0.470	0.305	BRLS-832-130
	10-32 UNF	.020 - .130	.2969-.3029	0.296	0.030	0.415	0.475	0.315	BRLS-1032-130
	10-32 UNF	.130 - .225	.2969-.3029	0.296	0.030	0.415	0.585	0.315	BRLS-1032-225
	1/4-20 UNC	.027 - .165	.3906-.3966	0.390	0.030	0.500	0.580	0.380	BRLS-420-165
	1/4-20 UNC	.165 - .260	.3906-.3966	0.390	0.030	0.500	0.680	0.380	BRLS-420-260
	5/16-18 UNC	.027 - .150	.5312-.5372	0.530	0.035	0.685	0.690	0.470	BRLS-518-150
	5/16-18 UNC	.150 - .312	.5312-.5372	0.530	0.035	0.685	0.805	0.425	BRLS-518-312
	3/8-16 UNC	.027 - .150	.5312-.5372	0.530	0.035	0.685	0.690	0.470	BRLS-616-150
3/8-16 UNC	.150 - .312	.5312-.5372	0.530	0.035	0.685	0.805	0.425	BRLS-616-312	
Metric	M4X0.7 ISO	0.50 - 2.00	6.75-6.90	6.73	0.76	9.91	10.67	7.75	BRLS-470-2.0
	M4X0.7 ISO	2.00 - 3.30	6.75-6.90	6.73	0.76	9.91	11.94	7.75	BRLS-470-3.3
	M5X0.8 ISO	0.50 - 3.30	7.60-7.75	7.52	0.76	10.54	12.07	8.00	BRLS-580-3.3
	M5X0.8 ISO	3.30 - 5.70	7.60-7.75	7.52	0.76	10.54	14.86	8.00	BRLS-580-5.7
	M6X1.0 ISO	0.70 - 4.20	10.00-10.15	9.91	0.76	12.70	14.73	9.65	BRLS-610-4.2
	M6X1.0 ISO	4.20 - 6.60	10.00-10.15	9.91	0.76	12.70	17.27	9.65	BRLS-610-6.6
	M8X1.25 ISO	0.70 - 3.80	13.50-13.65	13.46	0.89	17.40	17.53	11.94	BRLS-8125-3.8
	M8X1.25 ISO	3.80 - 7.90	13.50-13.65	13.46	0.89	17.40	20.45	10.80	BRLS-8125-7.9
	M10X1.5 ISO	0.70 - 3.80	13.50-13.65	13.46	0.89	17.40	17.53	11.94	BRLS-1015-3.8
	M10X1.5 ISO	3.80 - 7.90	13.50-13.65	13.46	0.89	17.40	20.45	10.80	BRLS-1015-7.9

Note 1: The standard material for the TW product line is 1010 steel with a RoHS compliant Zinc / Clear plating.
Note 2: Other material, finishes or design variations are available upon request.

RIVNUT® TW Low Profile Head

The TW (thin wall) line is designed as a lower cost alternative for applications with reduced load requirements, and with a wider grip range. The Böllhoff TW line is compatible with both spin-spin and spin-pull tooling. Shown below is the low profile head for applications where a minimal head height is required, as this fastener provides a nearly flush mount.

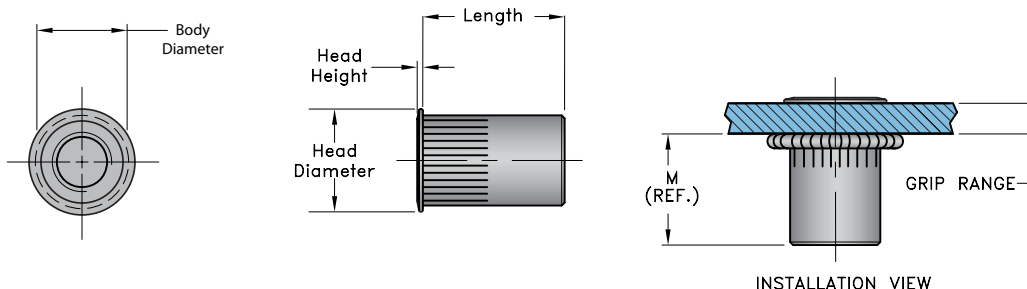

Class 2B or Metric Class 6H threads
Steel: C1010

Unified	Thread size	Grip Range	Hole Size min max	Body Diameter	Head Height	Head Diameter	Overall Length	Installed Length	Product Code
"K" Series	8-32 UNC	.020 - .080	.2656-.2716	0.265	0.019	0.310	0.420	0.305	BRKS-832-80
	8-32 UNC	.080 - .130	.2656-.2716	0.265	0.019	0.310	0.470	0.305	BRKS-832-130
	10-32 UNF	.020 - .130	.2969-.3029	0.296	0.019	0.340	0.475	0.315	BRKS-1032-130
	10-32 UNF	.130 - .225	.2969-.3029	0.296	0.019	0.340	0.585	0.315	BRKS-1032-225
	1/4-20 UNC	.027 - .165	.3906-.3966	0.390	0.022	0.455	0.580	0.380	BRKS-420-165
	1/4-20 UNC	.165 - .260	.3906-.3966	0.390	0.022	0.455	0.680	0.380	BRKS-420-260
	5/16-18 UNC	.027 - .150	.5312-.5372	0.530	0.022	0.595	0.690	0.470	BRKS-518-150
	5/16-18 UNC	.150 - .312	.5312-.5372	0.530	0.022	0.595	0.805	0.425	BRKS-518-312
	3/8-16 UNC	.027 - .150	.5312-.5372	0.530	0.022	0.595	0.690	0.470	BRKS-616-150
3/8-16 UNC	.150 - .312	.5312-.5372	0.530	0.022	0.595	0.805	0.425	BRKS-616-312	
Metric	M4X0.7 ISO	0.50 - 2.00	6.75-6.90	6.730	0.480	7.870	10.67	7.75	BRKS-470-2.0
	M4X0.7 ISO	2.00 - 3.30	6.75-6.90	6.730	0.480	7.870	11.94	7.75	BRKS-470-3.3
	M5X0.8 ISO	0.50 - 3.30	7.60-7.75	7.520	0.480	8.640	12.07	8.00	BRKS-580-3.3
	M5X0.8 ISO	3.30 - 5.70	7.60-7.75	7.520	0.480	8.640	14.86	8.00	BRKS-580-5.7
	M6X1.0 ISO	0.70 - 4.20	10.00-10.15	9.910	0.550	11.560	14.73	9.65	BRKS-610-4.2
	M6X1.0 ISO	4.20 - 6.60	10.00-10.15	9.910	0.550	11.560	17.27	9.65	BRKS-610-6.6
	M8X1.25 ISO	0.70 - 3.80	13.50-13.65	13.460	0.550	13.500	17.53	11.94	BRKS-8125-3.8
	M8X1.25 ISO	3.80 - 7.90	13.50-13.65	13.460	0.550	13.500	20.45	10.80	BRKS-8125-7.9
	M10X1.5 ISO	0.70 - 3.80	13.50-13.65	13.460	0.550	13.500	17.53	11.94	BRKS-1015-3.8
	M10X1.5 ISO	3.80 - 7.90	13.50-13.65	13.460	0.550	13.500	20.45	10.80	BRKS-1015-7.9

Note 1: The standard material for the TW product line is 1010 steel with a RoHS compliant Zinc / Clear plating.
Note 2: Other material, finishes or design variations are available upon request.

RIVNUT® TW Half Hex Body

The TW (thin wall) line is designed as a lower cost alternative for applications with reduced load requirements, and with a wider grip range. The Böllhoff TW line is compatible with both spin-spin and spin-pull tooling. Shown below is the half hex body for applications where higher spinout resistance is required.

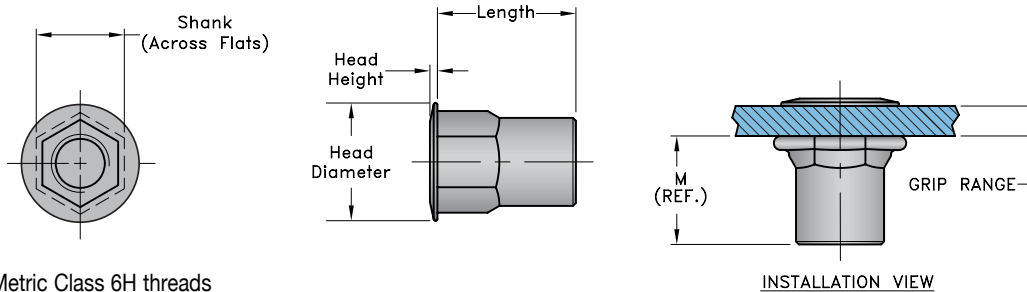

Class 2B or Metric Class 6H threads
Steel: C1010

Unified	Thread size	Grip Range	Hole Size min max	Across Flats	Head Height	Head Diameter	Overall Length	Installed Length	Product Code
"H" Series	8-32 UNC	.020 - .080	.250-.254	0.249	0.027	0.375	0.385	0.295	BRHS-832-80
	8-32 UNC	.080 - .130	.250-.254	0.249	0.027	0.375	0.435	0.295	BRHS-832-130
	10-32 UNF	.020 - .130	.281-.285	0.280	0.027	0.39	0.435	0.275	BRHS-1032-130
	10-32 UNF	.130 - .225	.281-.285	0.280	0.027	0.39	0.535	0.275	BRHS-1032-225
	1/4-20 UNC	.027 - .165	.375-.379	0.374	0.03	0.51	0.585	0.4	BRHS-420-165
	1/4-20 UNC	.165 - .260	.375-.379	0.374	0.03	0.51	0.685	0.4	BRHS-420-260
	5/16-18 UNC	.027 - .150	.500-.504	0.499	0.035	0.655	0.685	0.53	BRHS-518-150
	5/16-18 UNC	.150 - .312	.500-.504	0.499	0.035	0.655	0.845	0.515	BRHS-518-312
	3/8-16 UNC	.027 - .150	.500-.504	0.499	0.035	0.655	0.685	0.53	BRHS-616-150
	3/8-16 UNC	.150 - .312	.500-.504	0.499	0.035	0.655	0.845	0.515	BRHS-616-312
Metric	M4X0.7 ISO	0.50 - 2.00	6.35-6.45	6.35	0.68	9.53	9.78	7.49	BRHS-470-2.0
	M4X0.7 ISO	2.00 - 3.30	6.35-6.45	6.35	0.68	9.53	11.05	7.49	BRHS-470-3.3
	M5X0.8 ISO	0.50 - 3.30	7.14-7.24	7.10	0.68	9.91	11.05	6.99	BRHS-580-3.3
	M5X0.8 ISO	3.30 - 5.70	7.14-7.24	7.10	0.68	9.91	13.59	6.99	BRHS-580-5.7
	M6X1.0 ISO	0.70 - 4.20	9.53-9.63	9.50	0.76	12.96	14.86	10.16	BRHS-610-4.2
	M6X1.0 ISO	4.20 - 6.60	9.53-9.63	9.50	0.76	12.96	17.4	10.16	BRHS-610-6.6
	M8X1.25 ISO	0.70 - 3.80	12.70-12.8	12.70	0.89	16.64	17.4	13.46	BRHS-8125-3.8
	M8X1.25 ISO	3.80 - 7.90	12.70-12.8	12.70	0.89	16.64	21.46	13.08	BRHS-8125-7.9
	M10X1.5 ISO	0.70 - 3.80	12.70-12.8	12.70	0.89	16.64	17.4	13.46	BRHS-1015-3.8
	M10X1.5 ISO	3.80 - 7.90	12.70-12.8	12.70	0.89	16.64	21.46	13.08	BRHS-1015-7.9

Note 1: The standard material for the TW product line is 1010 steel with a RoHS compliant Zinc / Clear plating.
Note 2: Other material, finishes or design variations are available upon request.

TW

RIVNUT® HRT Steel

Advanced development of our existing RIVNUT® technology has resulted in a product with a high resistance thread (HRT) which uses advanced materials and processes to produce an enhanced, hardened, thread which significantly increases the mechanical performance of the blind rivet nut.

A lightweight, simple to install solution which allows use of fasteners up to and including property class 12.9 making it ideal for structural applications requiring higher joint tension and mechanical forces within the assembly.

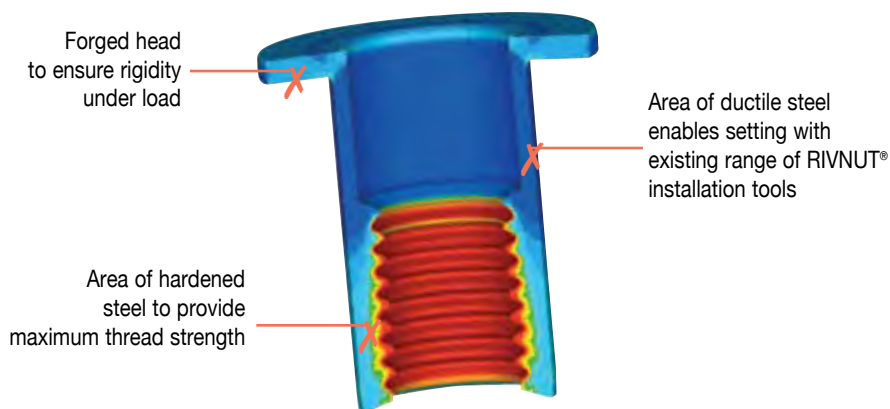

Steel: Property Class 12.9 Equivalent

The maximum acceptable tightening torque of a screw/nut assembly determines the preload developed in the joint. These values have been established in the standard ISO-898-1 / ISO-898-2(1) and require that in such a screwed joint it is desirable that when fatigue occurs the screw fails before the nut. As the preload in an assembly increases so the use of progressively higher strength fasteners is necessary. The table below shows the compatibility of steel RIVNUT® HRT with property class 12.9 bolts.

Thread diameter	Property class 8.8 bolt / Property class 8.8 bolt (N) ISO 898-1 / ISO 898-2		RIVNUT® HRT (N)
	Proofload of the screw (1)	Proofload of the nut	Proofload
M6	19,500	23,100	23,100
M8	35,500	42,500	42,500
M10	56,300	67,300	67,300
M12	81,800	100,300	100,300

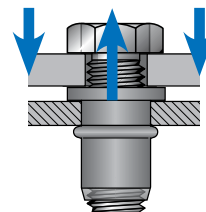

RIVNUT® HRT Steel

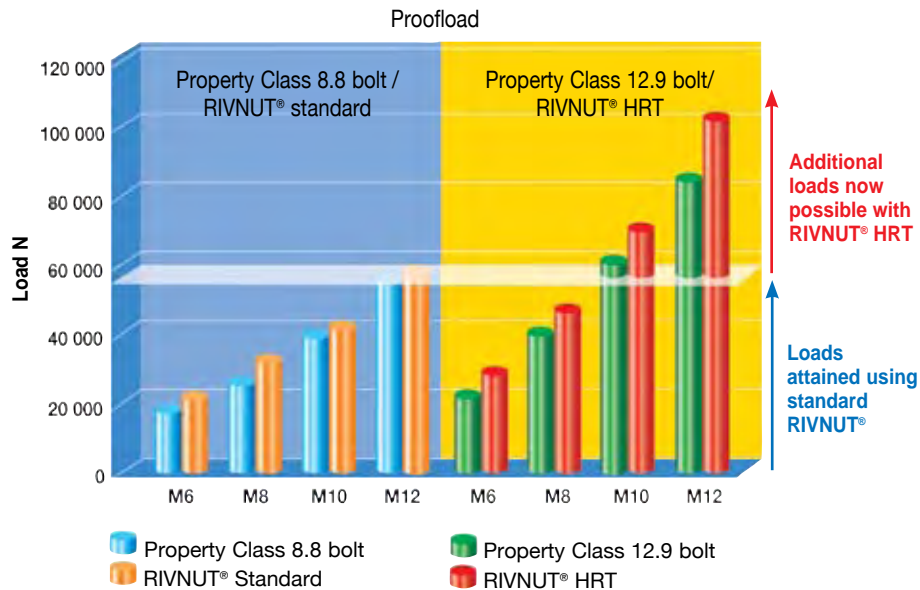

Technical features of RIVNUT® HRT Steel

- Material: Steel. A wide range of plating finishes are available including zinc or zinc nickel.
- Size range: M6 to M12.
- Body styles: RIVNUT® HRT is available only with a hexagonal body and flat head .
- Special shapes are available on request.
A/F and hole dimensions are shown in the table below and are interchangeable with standard RIVNUT® products.

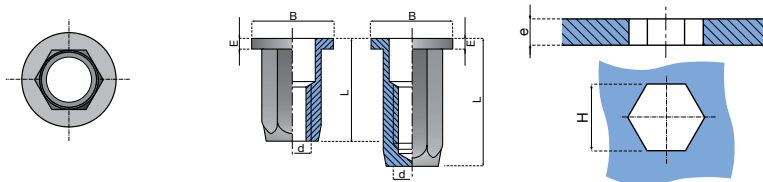

Thread Diameter d	Grip Range e	Hex Hole A/F H	Head Diameter B	Head Thickness E	Overall Length L	Product Code
M6	1.0 – 3.0	9	14	1.5	18.6	2324 106 0030
M8	1.0 – 3.0	11	17	1.5	23.6	2324 108 0030
M10	1.0 – 3.5	13	20	2.0	27.0	2324 110 0035
M12	1.0 – 4.0	16	24	2.0	33.0	2324 110 0040

Unit: mm

Applications

- Use to replace traditional fastening methods for proof loads above 54 kN:
Examples: to replace welded fasteners used on excavators, public works equipment and structural joints using M10 and M12 in property class 12.9 bolt.
- Reducing dimensions and weight of fastenings:
Example: for a fastening carrying a preload of 35 kN, the traditional solution was to use an M12 bolt in property class 8.8 with a corresponding nut. Today you can replace this with an M8 bolt in property class 12.9. Assembled with an M8 RIVNUT® HRT blind rivet nut to carry the same load.

RIVNUT® HRT Aluminum

RIVNUT® HRT produced in aluminum combines of lightweight material with our unique process for high strength threads. The use of RIVNUT® HRT aluminum provides the many advantages of an aluminum fastening but is now combined with the strength required to be compatible with property class 8.8 bolts. Highly corrosion resistant, this blind rivet nut can be used in aluminum, plastic or coated steel sheets for external applications.

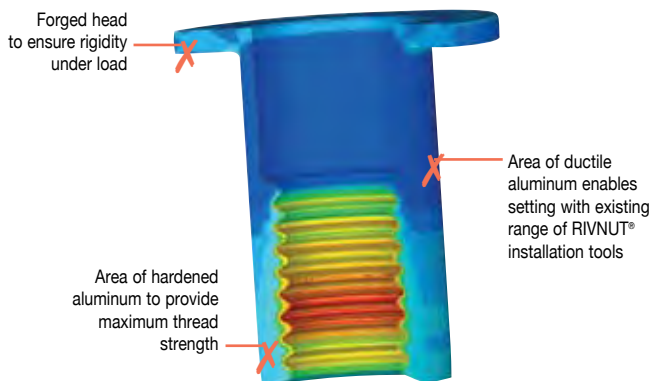

Aluminum: Property Class 8.8 Equivalent

The maximum acceptable tightening torque of a screw/nut assembly determines the preload developed in the joint. These values have been established in the standard ISO-898-1/ ISO-898-2 (1) and require that in such a bolted joint it is desirable that when fatigue occurs the bolt fails before the nut. As the preload in an assembly increases so the use of progressively higher strength fasteners is necessary. The table below shows the compatibility of RIVNUT® HRT aluminum with property class 8.8 bolt.

Thread diameter	Property Class 8.8 bolt / Nut Property Class 8.8 (N) ISO 898-1 / ISO 898-2		RIVNUT® HRT (N)
	Proofload of the bolt (1)	Proofload of the nut	Proofload
M6	11,600	16,100	17,200
M8	21,200	29,200	31,800

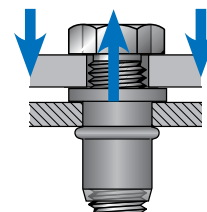

RIVNUT® HRT Aluminum

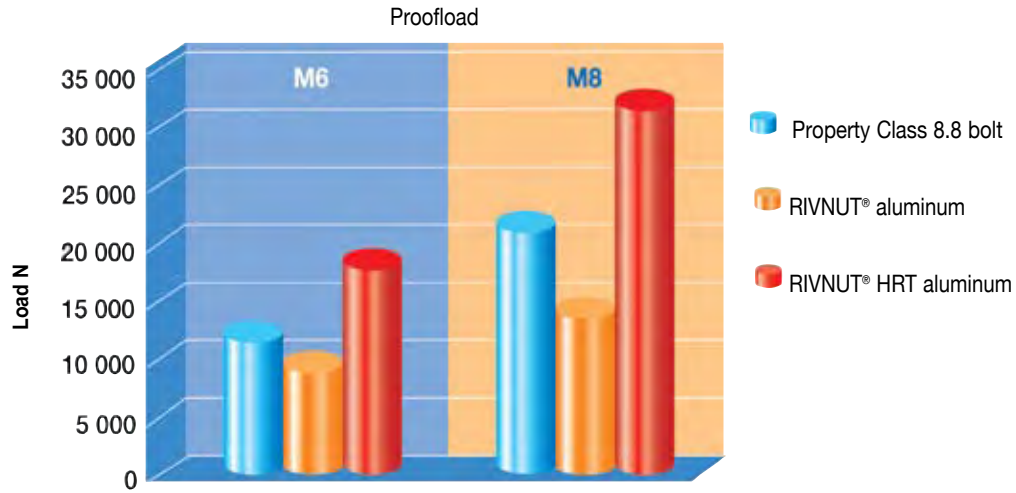

Aluminum RIVNUT® HRT technical features

- Material: aluminum 5056.
 - Size range: M6 to M8.
 - Body styles: RIVNUT® HRT is available only with an hexagonal body and flat head.
 - Special shapes are available on request.
- A/F and hole dimensions are shown in the table below and are interchangeable with standard RIVNUT® products.

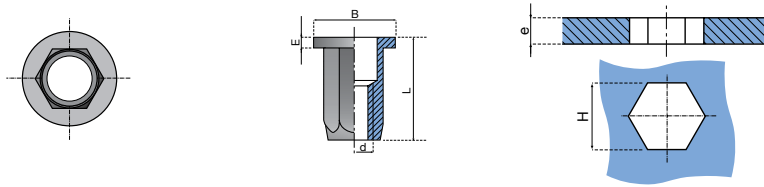

Thread Diameter d	Grip Range e	Hex Hole A/F H	Head Diameter B	Head Thickness E	Overall Length L	Product Code
M6	0.5 – 3.0	9	14	1.5	18.6	2324 006 0030
M8	0.5 – 3.0	11	17	1.5	23.6	2324 008 0030

Unit: mm

Applications

- Weight saving RIVNUT® blind fastening compatible with Property Class 8.8:
Example: directly replace an hexagonal M6 nut with HRT and achieve a weight reduction of 63 %.
- Corrosion resistant solution for external applications:
Example: traffic signs; joining aluminum tubes on decorative architecture; replace expensive stainless steel fixings.
- High resistant and easy to recycle joints for mobile aluminum structures (car body construction, commercial vehicles, railed vehicles, ...)

RIVNUT® Design Options

The standard RIVNUT® fasteners shown in this catalog will meet a wide range of application requirements. When a special dimension, head shape, thread or secondary feature is required, we welcome the opportunity to design a special RIVNUT® fastener to meet your requirements.

Head Shape or Size

RIVNUT® heads can be produced in round, square, hex or oval to fit into corresponding recesses in the parent material to increase spin-out resistance. Round head diameters can be increased to provide greater load-bearing surface. Head height can be increased to meet gasket-sealing requirements or be designed to meet requirements for compression limiting within the mating part.

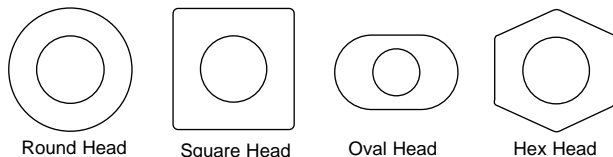

Knurls or Seals

Various knurls can be incorporated under the head of the RIVNUT® to increase spinout resistance. PVC foam seals can be pre-applied to the under head of the RIVNUT® to provide a seal against water, air, dust and non petroleum-based liquids. Rubber "O" rings can be applied to an under head ring groove to seal petroleum-based liquids and certain chemicals.

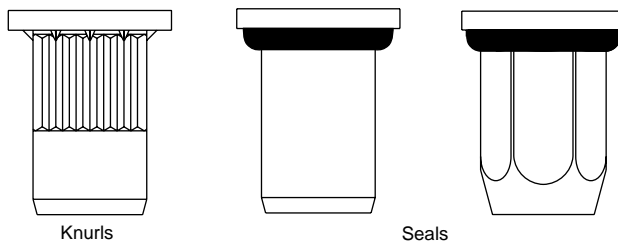

Grip Range

The grip range of the RIVNUT® is set to specific minimum and maximum dimensions as shown in this catalog. The starting point of the grip range can be adjusted to meet application requirements, provide increased pull-out resistance or help to reduce the number of different grip fasteners required for the application. In the example at the right a 1st and 2nd grip part is shown. The special mid grip part can be designed to replace both standard parts.

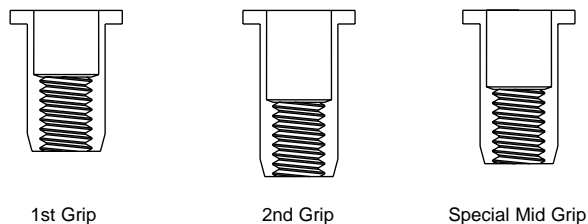

Length and Closed Ends

The length of the RIVNUT® can be reduced to allow the RIVNUT® to fit into limited access applications or increased to provide additional threads. The length of the RIVNUT® can also be increased to engage the opposite side of an extrusion to increase torsional stability. The RIVNUT® can incorporate a closed end design to prevent leakage of air, gas, dust or water past the threads.

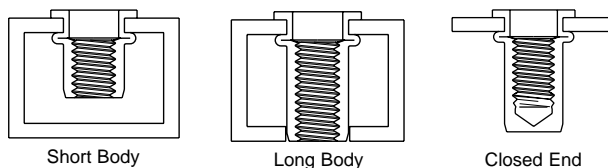

Finish

RIVNUT® fasteners can be ordered with a wide variety of finishes and coatings. Please contact us for assistance with your selection.

SPECIALS

RIVNUT® Specials

RIVNUT® with a large diameter head with under head and shank knurls provides large bearing surface and exceptional spin out in plastics. This fastener is ideal for applications in thermo plastic and other glass reinforced plastic materials.



RIVNUT® Teardrop is a single lug fastener providing positive torque-out resistance, without the need for a keyway or special hole preparation. (Thread locking feature also available)



RIVNUT® with a secondary floating nut is ideal for applications with mating part alignment issues. This fastener also features a knurled body for increased spin out resistance and a secondary shear sleeve applied to the counterbore to increase shear strength.



RIVNUT® with oval head and tapered shank. This fastener is used in a plastic radiator mounting structure. The oval head fits into a matching oval recess to prevent spin out. The smooth body eliminates stress fracturing concerns and is excellent for use in SMC plastic.



RIVNUT® with a pre-applied PVC foam sealed head is designed to seal against dust, water, air and non-petroleum based liquids. The PVC foam seal is bonded to the fastener and seals the circumference of the hole during the installation of the fastener.



RIVNUT® UNILOCK® fasteners feature an end of shank crimped prevailing torque locking element that meets MIL-N-25027 thread locking requirements. The “keyed” underhead projection fits into a mating key hole slot in the parent material preventing spin out under prevailing torque thread locking.



PLUSNUT® with a large diameter head and knurls under head provides exceptional spin-out and pull-out in plastics. This fastener is designed for use in blow molded plastics. The large head provides increased bearing surface for the mating part.



RIVNUT® AV anti-vibration fastener is made from thermoplastic elastomer and is installed with the mating screw. It incorporates a steel washer molded into the head. The internal metal molded-in-place nut portion contacts the underside of the washer during tightening of the mating screw so clamp load can be achieved.



RIVNUT® Power Tools

P2005 Spin-pull to Stroke Pneumatic/Hydraulic Tool

The P2005 is lighter, more ergonomic and user-friendly than any pull to stroke tool on the market. Böllhoff has incorporated our customers' requirements and recommendations into this new and easy to use tool. The P2005 tool installs the RIVNUT® or RIVSTUD® by pull to stroke control. The stroke of the tool is set to install the fastener in a specific thickness.

Installation Sequence

- Press the RIVNUT® or RIVSTUD® fastener threads against the tool mandrel for automatic spin on.
- Insert fastener into the hole in the parent material and pull the trigger.
- The P2005 installs the fastener and automatically reverses.

Features

- Single stage trigger controls complete installation sequence
- Automatic timed reverse spin and stop for maximum speed
- Installs 20 to 30 pieces per minute
- Ergonomic grip and balance for operator comfort
- Weight: 4.5 lbs. (2.36kg)
- Max. Stroke: .275 in. (7,0mm)
- Max. Pull Force: 4700 lbs. (17kN)
- 80 PSI (5.5 BAR) of clean dry air required for operation



P2007/P2007PN Spin-pull to Pressure Pneumatic/Hydraulic Tool

The P2007 (P2007PN for PLUSNUT® applications) is the most versatile and ergonomic pull to pressure tool on the market. It utilizes a single trigger control with an automatic spin off. This process ensures a reliable installation while minimizing installation time. The P2007 will install M3 – M10 RIVNUT® fasteners or RIVSTUD® fasteners into a variety of thicknesses using pull to pressure technology.

Features:

- Single stage trigger controls complete installation sequence
- Automatic timed reverse spin and stop for maximum speed
- Installs 20 to 30 pieces per minute
- Ergonomic grip and balance for operator comfort
- Lightweight and compact: 4.9 lbs. (2.2 kg)
- Max. Stroke: .275 in. (7mm), (14mm for P2007PN)
- Max. Pull Force: 4700 lbf. (21 kN)
- 80 PSI (5.5 Bar) of clean dry air required for operation



Note 1: See page 29 for a fastener/tool selection guide

Note 2: Part Numbers for tools shown on this page are for the tool only. Specific pull up studs or mandrels and nose anvils to be used with different thread size fasteners can be ordered separately by contacting Böllhoff Inc. or our Authorized Distributor.

RIVNUT® Power Tools

New! P1007 Lightweight Spin-pull to Pressure Pneumatic/Hydraulic Tool

The P1007 operates in the same manner as the P2007, but is lighter and more compact. The P1007 will install M3 – M6 RIVNUT® fasteners or RIVSTUD® fasteners into a variety of thicknesses using pull to pressure technology.

Features:

- Single stage trigger controls complete installation sequence
- Automatic timed reverse spin and stop for maximum speed
- Installs 20 to 30 pieces per minute
- Ergonomic grip and balance for operator comfort
- Lightweight and compact: 4.0 lbs. (1.8 kg)
- Max. Stroke: .275 in. (7mm)
- Max. Pull Force: 2900 lbf. (13 kN)
- 80 PSI (5.5 Bar) of clean dry air required for operation



New! P3007/P3007PN High Strength Spin-pull to Pressure Pneumatic/Hydraulic Tool

The P3007 is the newest addition to the Böllhoff installation tooling line. It operates in the same manner as the P2007 and P1007, but has the capability to pull up to 35 kN. The P3007 will install M10 – M12 HRT RIVNUT® or RIVSTUD® fasteners into a variety of thicknesses using pull to pressure technology.

Features:

- Single stage trigger controls complete installation sequence
- Automatic timed reverse spin and stop for maximum speed
- Installs 20 to 30 pieces per minute
- Ergonomic grip and balance for operator comfort
- Compatible with M10 and M12 RIVNUT® HRT products
- Max. Stroke: .275 in. (7mm)
- Max. Pull Force: 7,800 lbf. (35 kN)
- 80 PSI (5.5 Bar) of clean dry air required for operation



Note 1: See page 29 for a fastener/tool selection guide

Note 2: Part Numbers for tools shown on this page are for the tool only. Specific pull up studs or mandrels and nose anvils to be used with different thread size fasteners can be ordered separately by contacting Böllhoff Inc. or our Authorized Distributor.

RIVNUT® Power Tools

EPK C Electronically Operated Spin-pull to Pressure Pneumatic/Hydraulic Tool

The EPK C tool installs the RIVNUT® or RIVSTUD® fastener by pull to pressure control. Once the pull to pressure force is set the EPK C tool will install the fastener into single, multiple or variable thickness materials without further adjustment. The EPK C tool features integrated process monitoring of stroke and pressure installation to assure quality installations.

Installation Sequence

- Press the RIVNUT® or RIVSTUD® fastener against the tool mandrel for automatic spin on.
- Insert the fastener into the hole in the parent material and pull the trigger.
- The tool installs the fastener and automatically reverses.

Features

- Electronic Controls with process monitoring
- Installs 20 to 30 pieces per minute
- Available in pistol or inline version
- Tool Weight (pistol version): 5.1 lbs. (2.3 kg)
- Max. Stroke: .250 in. (6.5 mm)
- Max. Pull Force: 4,700 lbs. (21 kN)
- 90 PSI (6.0 BAR) of clean dry air
- 230V-single phase 50/60HZ

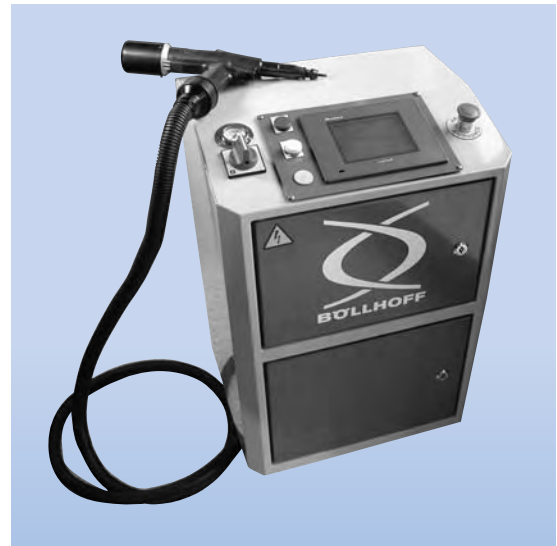

SAC310: Modular, semi-automatic setting head (spindle stroke principle, hydraulic pneumatic)

The SAC310 is a light, compact setting head designed for the semi-automatic installation of RIVNUT® fasteners and RIVSTUD® fasteners. The SAC310 will install fasteners into components that can only be accessed from one side by using pull to pressure technology. The system is designed in modules which means that either single-head or multi-head units can be built. Standard modules can be used to build stand alone workstations or to incorporate a unit into a production line.

Installation Sequence

- RIVNUT® automatically loads with mandrel pressure
- The fastener is placed into the hole
- Automatic installation and reversal is activated

Features

- Automatic loading by mandrel pressure
- Pneumatic/Hydraulic setting
- Automatic spin off
- Process monitoring available
- Data output feature available

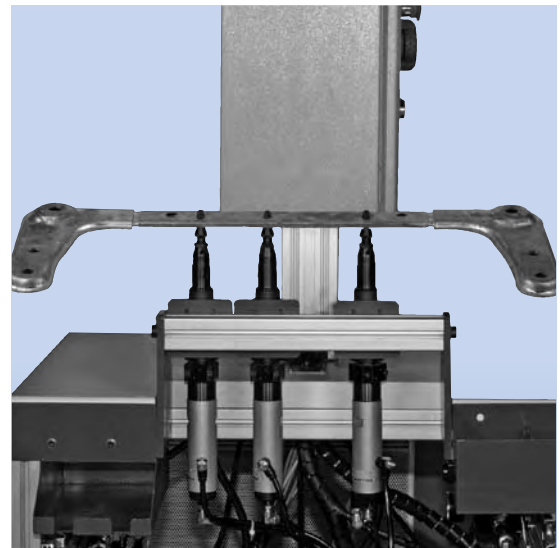

Note 1: See page 29 for a fastener/tool selection guide

Note 2: Part Numbers for tools shown on this page are for the tool only. Specific pull up studs or mandrels and nose anvils to be used with different thread size fasteners can be ordered separately by contacting Böllhoff Inc. or our Authorized Distributor.

RIVNUT® Power Tools

HSA 803 Spin-pull to Pressure Pneumatic/ Hydraulic Automation Tool

The HSA 803 installs the RIVNUT® by pull to pressure control. Once the pressure is set the HSA 803 will install the fastener into single, variable or multiple thickness materials without further adjustment. The HSA 803 is available in "pick and place" and self feeding versions. The tool features process monitoring to assure proper part feeding, automatic thread on, stroke distance, and pressure pull. A single tool or complete system including process monitoring is available for robotic or fixtured applications.

Installation Sequence

- RIVNUT® self feeds and is threaded onto tool mandrel.
- The fastener is placed in the hole and automatic installation and reversal is activated.

Features

- Installs 20 pieces per minute
- Auto feed or pick and place capability
- Full electronic controls and process monitoring
- Quick change mandrel requires no tools
- Axis compensator for robotic installations
- Slip shaft for cross-thread detection

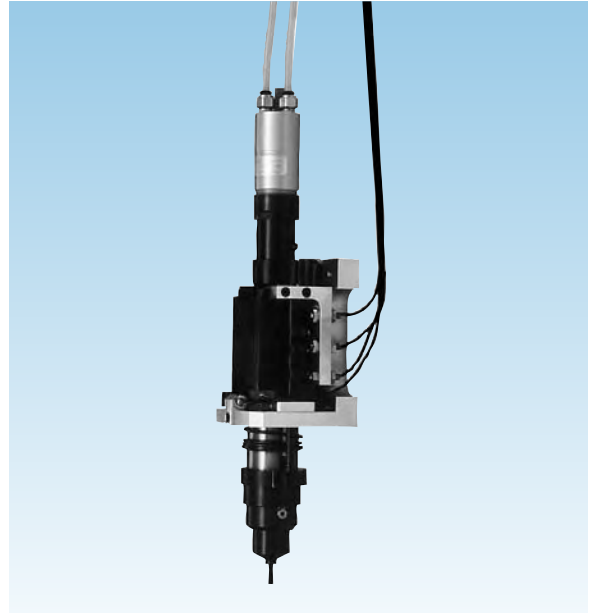

C302 P Spin-pull to Stroke Pneumatic Tool

The C302 P tool installs the RIVNUT® or PLUSNUT® by pull to stroke distance control. Once the stroke distance is set, the tool will install the fastener into a specific material thickness. The C302 P tool is completely pneumatic. The long stroke capability of the C302 P enables it to install the PLUSNUT® fastener. The C302 P tool may also be set up to install the fastener by pull to pressure upset.

Installation Sequence

- 1/4 turn the RIVNUT® or PLUSNUT® fastener onto the tool mandrel.
- Place the fastener into the hole in the parent material and pull the trigger to the first stop for installation.
- Pull the trigger to the final stop to reverse from the installed fastener.

Features

- Inline version also available
- Installs both RIVNUT® and PLUSNUT® fasteners
- Fully pneumatic tool for maintenance simplicity
- Installs 15 to 20 pieces per minute
- Weight: 6.1 lbs. (2.8 kg)
- Max. Stroke: .500 in. (12.7 mm)
- Max. Pull Force: 6000 lbs. (26.7 kN)
- 75 PSI (5.2 BAR) of clean lubricated air required for operation



Note 1: See page 29 for a fastener/tool selection guide

Note 2: Part Numbers for tools shown on this page are for the tool only. Specific pull up studs or mandrels and nose anvils to be used with different thread size fasteners can be ordered separately by contacting Böllhoff Inc. or our Authorized Distributor.

RIVNUT® Hand Tools

C6000/C7000 Single Lever Type

The C6000/C7000 is a lever type hand tool that is operator pressure controlled and designed to install RIVNUT® or PLUSNUT® fasteners. It features a plunger rotation knob for spin on and spin off of the RIVNUT® or PLUSNUT®.

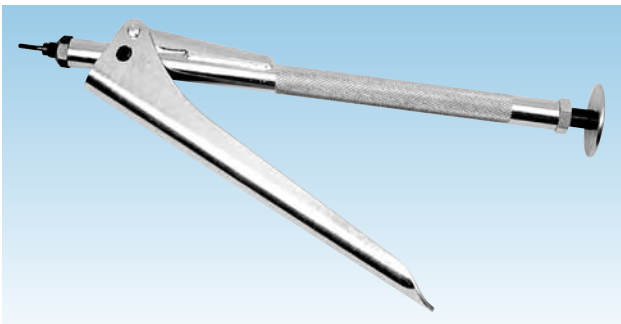

C1000 Wrench Type Stroke Tool

The C1000 wrench type tool installs the RIVNUT® and PLUSNUT® fasteners by using two simple wrenches. As the nut on the top of the tool is turned the shaft of the tool exerts a linear pull stroke on the fastener.

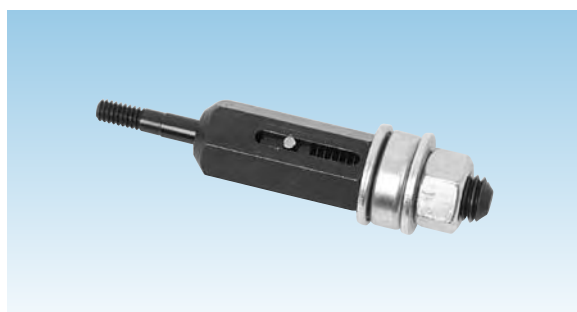

C722/C845 Wrench Type Stroke Tool

The C722 wrench type tool installs the RIVNUT® or PLUSNUT® using a simple wrench to hold the tool and a hex key to apply torque. As the hex key is turned the tool exerts a linear pull stroke to install the RIVNUT® or PLUSNUT®.

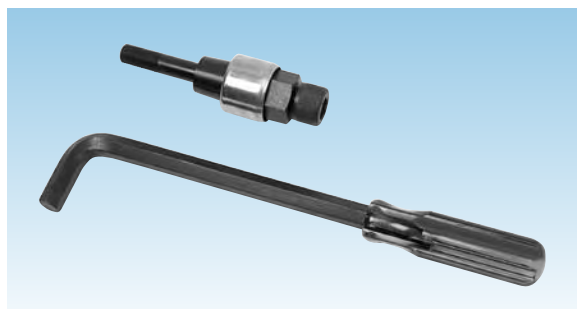

Note 1: See page 29 for a fastener/tool selection guide

Note 2: Part Numbers for tools shown on this page are for the tool only. Specific pull up studs or mandrels and nose anvils to be used with different thread size fasteners can be ordered separately by contacting Böllhoff Inc. or our Authorized Distributor.

Tool Warranty: For a period of one year from date of sale, Böllhoff Inc. warrants to the original retail purchaser that the installation tools contained in this catalog will be free from defects in material and workmanship, provided that they are used in accordance with the guidelines contained in this catalog. Böllhoff will at its sole option repair, replace or rework the products at a cost not to exceed the invoice price of the products. This warranty is in lieu of all other warranties, expressed or implied, and in no way will Böllhoff be held liable for incidental or consequential damages arising from any defect or failure in its products.

RIVNUT® Fastener/Tool Selection Guide

The following Fastener/Tool Selection Guide indicates the fastener and thread size capability of each Böllhoff tool. This chart covers products made from steel only. For assistance in selecting tools to install aluminum or stainless steel products please contact Böllhoff Inc. or our Authorized Distributor.

To use the guide please do the following:

- Locate the fastener type in the top row of the chart.
- Locate the tool you are interested in along the left hand column.
- Select the intersecting data block. Each block contains the range of thread sizes that the tool will install of that particular fastener type.

	RIVNUT®	PLUSNUT®	TW	HRT	RIVKLE®
C722	5/16" - 1/2" M7 - M12	5/16" - 3/8" M8 - M10	5/16" - 1/2" M7 - M12		5/16" - 1/2" M7 - M12
C845	#4-40 - 1/4" M3 - M6		#4-40 - 1/4" M3 - M6		#4-40 - 1/4" M3 - M6
C1000		#4-40 - 1/4" M4 - M6			
C6000	#4-40 - 1/4" M3 - M6		#4-40 - 1/4" M3 - M6		#4-40 - 1/4" M3 - M6
C7000		#4-40 - #10-32 M4 - M5			
C302	#4-40 - 5/16" M3 - M8	#4-40 - 3/8" M5 - M10	#4-40 - 5/16" M3 - M8	#4-40 - 1/4" M3 - M6	#4-40 - 3/8" M3 - M6
P1007	#4-40 - 1/4" M3 - M6		#4-40 - 1/4" M3 - M6		#4-40 - 1/4" M3 - M10
P2005	#4-40 - 3/8" M3 - M10		#4-40 - 1/2" M3 - M12	1/4" - 5/16" M6 - M8	#4-40 - 1/2" M3 - M12
P2007	#4-40 - 5/16" M3 - M8		#4-40 - 3/8" M3 - M10	1/4" - 5/16" M6 - M8	#4-40 - 5/16" M3 - M8
P2007PN		#4-40 - 5/16" M5 - M8			
P3007	5/16" - 1/2" M8 - M12			5/16" - 1/2" M8 - M12	5/16" - 1/2" M8 - M12
P3007 PN		5/16" - 1/2" M8 - M12			
EPKC	#4-40 - 5/16" M3 - M8	#4-40 - 3/8" M3 - M10	#4-40 - 3/8" M3 - M10	1/4" - 5/16" M6 - M8	#4-40 - 5/16" M3 - M8
EPK HP	5/16" - 1/2" M7 - M12			5/16" - 1/2" M8 - M12	5/16" - 1/2" M7 - M12
SAC310	#6-32 - 3/8" M4 - M10		#6-32 - 3/8" M4 - M10	1/4" - 5/16" M6 - M8	#6-32 - 3/8" M4 - M10
HSA 803	#8-32 - 3/8" M4 - M10		#8-32 - 3/8" M4 - M10	1/4" - 5/16" M6 - M8	#8-32 - 3/8" M4 - M10

RIVNUT® Fastener Engineering Data - Unified Thread

Upset Load (lbs.)						
RIVNUT® Size	Aluminum		Steel		Stainless Steel	
	Min. Grip	Max. Grip	Min. Grip	Max. Grip	Min. Grip	Max. Grip
#4-40	400	450	700	800	800	900
#6-32	500	600	850	1000	1000	1300
#8-32	600	700	1000	1250	1400	1650
#10-32	750	800	1300	1500	1900	2000
1/4-20	1300	1450	2300	2610	3300	3400
5/16-18	1900	2150	3300	3650	4800	5600
3/8-16	2570	2700	4965	5325	6100	6660
1/2-13	3000	3400	5800	6300	7200	7600

Fig. 1

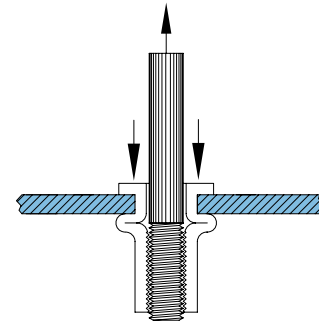

Ultimate thread strength (lbs.)						
RIVNUT® Size	Aluminum		Steel		Stainless Steel	
	Min. Grip	Max. Grip	Min. Grip	Max. Grip	Min. Grip	Max. Grip
#4-40	675	575	1180	1000	1600	1300
#6-32	964	820	1705	1450	2400	2000
#8-32	1095	935	1920	1630	3000	2200
#10-32	1600	1450	3000	2500	4000	3500
1/4-20	2500	2400	5240	4520	6000	5100
5/16-18	4000	3700	7625	6300	8700	7500
3/8-16	4700	4450	11500	10450	11700	9650
1/2-13	7900	6400	17250	14500	NA	NA

Fig. 2

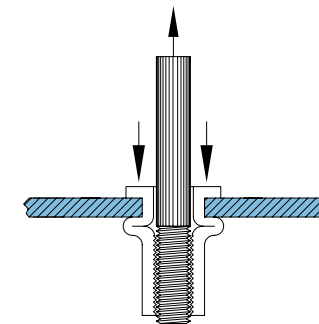

Ultimate tensile strength (lbs.)			
RIVNUT® Size	Aluminum	Steel	Stainless Steel
#4-40	261	458	621
#6-32	373	656	889
#8-32	485	853	1153
#10-32	617	1085	1470
1/4-20	1150	1850	2510
5/16-18	1600	2750	3730
3/8-16	2075	3900	5280
1/2-13	3100	4900	NA

Fig. 3

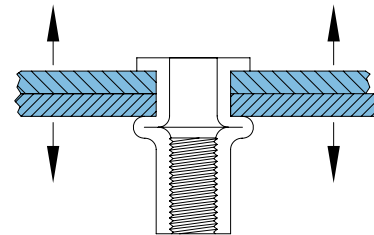

Ultimate shear strength (lbs.)			
RIVNUT® Size	Aluminum	Steel	Stainless Steel
#4-40	158	316	515
#6-32	230	460	749
#8-32	294	588	958
#10-32	374	748	1220
1/4-20	710	1100	1790
5/16-18	930	1750	2850
3/8-16	1260	2420	3940
1/2-13	1270	2440	3970

Fig. 4

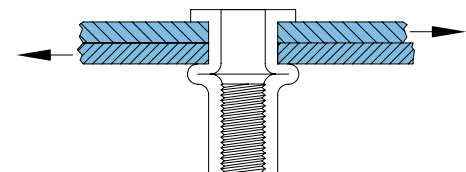

Aluminum RIVNUT® fasteners were tested in 2024-T4 aluminum plates. Steel RIVNUT® fasteners were tested in steel plates. Stainless steel RIVNUT® fasteners were tested in stainless steel plates. These values are averages only - certain variations must be expected in practice. NA - Test data not available

RIVNUT® Fastener Engineering Data - Metric Thread

Upset Load (N) See Fig. 1

RIVNUT® Size	Aluminum		Steel		Stainless Steel	
	Min. Grip	Max. Grip	Min. Grip	Max. Grip	Min. Grip	Max. Grip
M3 x 0.5	925	1059	1859	1957	3149	3447
M4 x 0.7	2678	3221	4915	5089	7620	8020
M5 x 0.8	4106	4555	7549	8332	9684	11717
M6 x 1.0	6210	6806	10903	12273	16116	16974
M8 x 1.25	8314	9074	13434	16214	18927	21627
M10 x 1.50	9194	9995	15071	16556	20146	21863
M12 x 1.75	19572	20795	32490	35399	42227	51288

Fig. 1

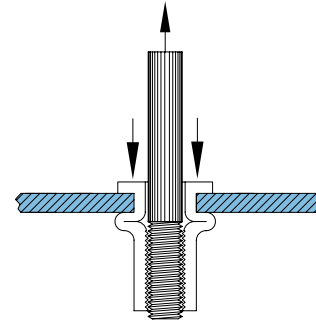

Ultimate thread strength (N) See Fig. 2

RIVNUT® Size	Aluminum		Steel		Stainless Steel	
	Min. Grip	Max. Grip	Min. Grip	Max. Grip	Min. Grip	Max. Grip
M3 x 0.5	2300	1984	5075	4266	7878	7495
M4 x 0.7	5342	5053	9924	9617	13936	12330
M5 x 0.8	8251	7308	13727	14457	23100	19034
M6 x 1.0	10987	11121	23095	21218	30737	30350
M8 x 1.25	20150	18393	28736	25764	44393	39131
M10 x 1.50	25253	18651	33793	27623	50042	49446
M12 x 1.75	42779	35644	70135	62796	99694	88964

Fig. 2

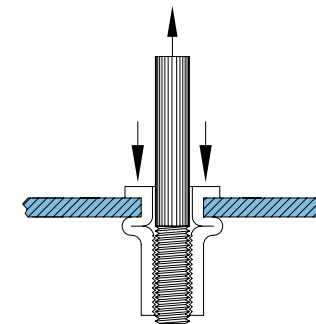

Ultimate tensile strength (N) See Fig. 3

RIVNUT® Size	Aluminum	Steel	Stainless Steel
M3 x 0.5	792	1503	2037
M4 x 0.7	1846	3447	5107
M5 x 0.8	2576	4889	7082
M6 x 1.0	4066	7709	10440
M8 x 1.25	5743	10765	14795
M10 x 1.50	6859	13011	17842
M12 x 1.75	12927	22370	33526

Fig. 3

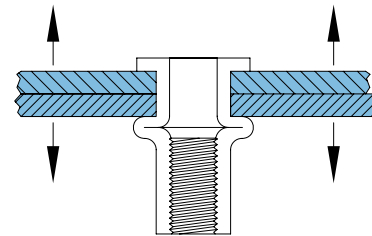

Ultimate shear strength (N) See Fig. 4

RIVNUT® Size	Aluminum	Steel	Stainless Steel
M3 x 0.5	414	1223	1899
M4 x 0.7	1223	2451	3541
M5 x 0.8	2353	3416	4733
M6 x 1.0	2629	4430	6761
M8 x 1.25	3661	8558	12922
M10 x 1.50	5013	9123	12001
M12 x 1.75	9163	13100	21218

Fig. 4

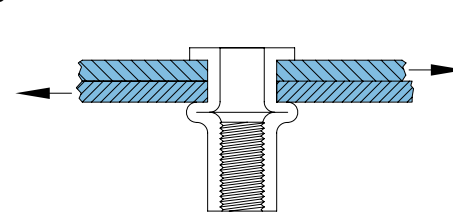

Aluminum RIVNUT® fasteners were tested in 2024-T4 aluminum plates. Steel RIVNUT® fasteners were tested in steel plates. Stainless steel RIVNUT® fasteners were tested in stainless steel plates. These values are averages only - certain variations must be expected in practice. NA - Test data not available

RIVNUT® Fastener Engineering Data - Unified Thread

Fig. 5

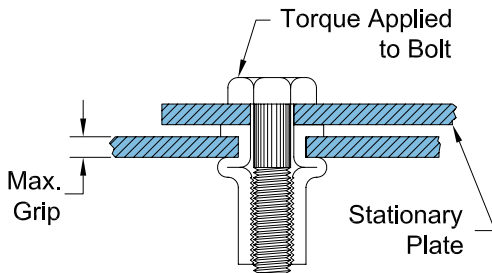

Torque strength data

Torque - axial load relationship

Used as nut plates, RIVNUT® fasteners may be safely loaded to torque equivalent of their maximum upset loads. Surpassing these loads will cause the screw to break, or the RIVNUT® will continue to upset until ultimate strip load is attained.

Because of the many variables such as type of lubrication, plating, type and property class of screw or bolt, it is recommended that a pilot test be conducted to determine the optimum assembly torque.

Torque Equiv. of Max. Upset Load (Lb.-In.)			
RIVNUT® Size	8	15	15
#4-40	8	15	15
#6-32	12	24	30
#8-32	16	38	45
#10-32	25	45	60
1/4-20	60	130	160
5/16-18	100	156	260
3/8-16	190	344	400
1/2-13	350	660	NA

Fig.6

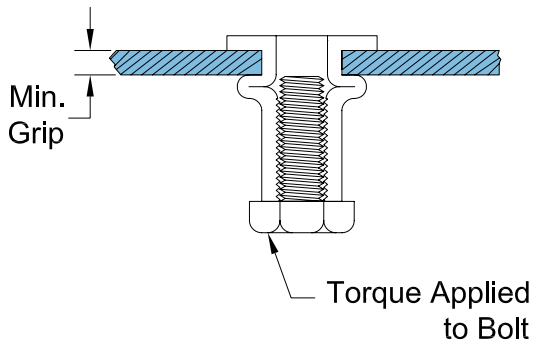

RIVNUT® torque-out strength

Although RIVNUT® fasteners are not normally used as shown in this view, it is used to illustrate the effect of accidental imposition of torque by: over-length screw bottoming in a blind end RIVNUT®; unthreaded shank area of an insufficiently threaded screw bottoming in the first thread of a RIVNUT®; cross threading in inserting screw.

RIVNUT® Size	Torque Required to Turn RIVNUT® (Lb.-In.)					
	Aluminum		Steel		Stainless Steel	
	Key	Keyless	Key	Keyless	Key	Keyless
#4-40	9	4	20	8	45	8
#6-32	12	4	29	13	46	15
#8-32	20	9	34	21	66	38
#10-32	22	12	43	23	77	38
1/4-20	55	30	93	51	134	78
5/16-18	101	46	176	70	360	115
3/8-16	116	83	361	131	400	201
1/2-13	216	130	NA	300	NA	NA

Aluminum RIVNUT® fasteners were tested in 2024-T4 aluminum plates. Steel RIVNUT® fasteners were tested in steel plates. Stainless steel RIVNUT® fasteners were tested in stainless steel plates. These values are averages only - certain variations must be expected in practice. NA - Test data not available

RIVNUT® Fastener Engineering Data - Metric Thread

Fig. 5

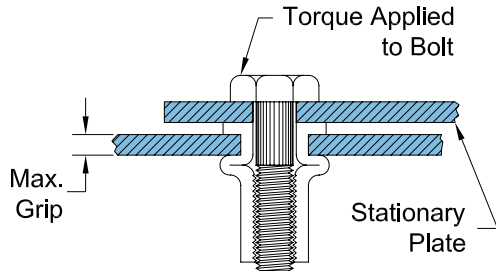

Torque strength data

Torque - axial load relationship

Used as nut plates, RIVNUT® fasteners may be safely loaded to torque equivalent of their maximum upset loads. Surpassing these loads will cause the screw to break, or the RIVNUT® will continue to upset until ultimate strip load is attained.

Because of the many variables such as type of lubrication, plating, type and property class of screw or bolt, it is recommended that a pilot test be conducted to determine the optimum assembly torque.

Torque Equiv. of Max. Upset Load (N)			
RIVNUT® Size	Aluminum	Steel	Stainless Steel
M3 x 0.	0.9	1.5	2.1
M4 x 0.7	2.6	2.9	5.4
M5 x 0.8	3.5	10.4	12.4
M6 x 1.0	10.6	13.7	15.1
M8 x 1.25	23.5	32.1	46.5
M10 x 1.50	25.8	35.3	52.9
M12 x 1.75	56.3	71.2	107.7

Fig.6

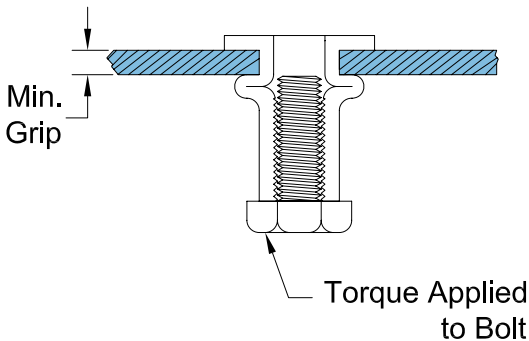

RIVNUT® torque-out strength

Although RIVNUT® fasteners are not normally used as shown in this view, it is used to illustrate the effect of accidental imposition of torque by: over-length screw bottoming in a blind end RIVNUT®; unthreaded shank area of an insufficiently threaded screw bottoming in the first thread of a RIVNUT®; cross threading in inserting screw.

Torque Required to Turn RIVNUT® (N)						
RIVNUT® Size	Aluminum		Steel		Stainless Steel	
	Key	Keyless	Key	Keyless	Key	Keyless
M3 x 0.5	1.4	0.3	2.4	0.7	4.4	1.1
M4 x 0.7	2.0	1.1	3.6	1.4	6.0	2.4
M5 x 0.8	3.3	2.0	11.3	2.8	13.4	4.5
M6 x 1.0	10.6	4.5	16.0	5.5	19.0	8.2
M8 x 1.25	12.7	6.0	30.3	7.2	37.7	18.2
M10 x 1.50	13.6	7.9	40.2	14.0	60.1	22.1
M12 x 1.75	48.8	26.7	53.3	38.0	79.3	59.7

Aluminum RIVNUT® fasteners were tested in 2024-T4 aluminum plates. Steel RIVNUT® fasteners were tested in steel plates. Stainless steel RIVNUT® fasteners were tested in stainless steel plates. These values are averages only - certain variations must be expected in practice. NA - Test data not available

Decimal Equivalents

Decimal Equivalents - Lettered Drills					
No. Drill	In. Diam.	No. Drill	In. Diam.	No. Drill	In. Diam.
A	0.234	J	0.277	S	0.348
B	0.238	K	0.281	T	0.358
C	0.242	L	0.29	U	0.368
D	0.246	M	0.295	V	0.377
E	0.25	N	0.302	W	0.386
F	0.257	O	0.316	X	0.397
G	0.261	P	0.323	Y	0.404
H	0.266	Q	0.332	Z	0.413
I	0.272	R	0.339		

Decimal Equivalents - Numbered Drills							
No. Drill	Size In.	No. Drill	Size In.	No. Drill	Size In.	No. Drill	Size In.
1	0.2280	21	0.1590	41	0.0960	61	0.0390
2	0.2210	22	0.1570	42	0.0935	62	0.0380
3	0.2130	23	0.1540	43	0.0890	63	0.0370
4	0.2090	24	0.1520	44	0.0860	64	0.0360
5	0.2055	25	0.1495	45	0.0820	65	0.0350
6	0.2040	26	0.1470	46	0.0810	66	0.0330
7	0.2010	27	0.1440	47	0.0785	67	0.0320
8	0.1990	28	0.1405	48	0.0760	68	0.0310
9	0.1960	29	0.1360	49	0.0730	69	0.0292
10	0.1935	30	0.1285	50	0.0700	70	0.0280
11	0.1910	31	0.1200	51	0.0670	71	0.0260
12	0.1890	32	0.1160	52	0.0635	72	0.0250
13	0.1850	33	0.1130	53	0.0595	73	0.0240
14	0.1820	34	0.1110	54	0.0550	74	0.0225
15	0.1800	35	0.1100	55	0.0520	75	0.0210
16	0.1770	36	0.1065	56	0.0465	76	0.0200
17	0.1730	37	0.1040	57	0.0430	77	0.0180
18	0.1695	38	0.1015	58	0.0420	78	0.0160
19	0.1660	39	0.0995	59	0.0410	79	0.0145
20	0.1610	40	0.0980	60	0.0400	80	0.0135

Decimal Equivalent Chart					
Inch Fraction	Decimal Equivalent	Inch Fraction	Decimal Equivalent	Inch Fraction	Decimal Equivalent
1/64	0.1560	23/64	0.3594	45/64	0.7031
1/32	0.3120	3/8	0.3750	23/32	0.7188
3/64	0.0469	25/64	0.3906	47/64	0.7344
1/16	0.0625	13/32	0.4063	3/4	0.7500
5/64	0.0781	37/64	0.5781	49/64	0.7656
3/32	0.0937	7/16	0.4375	25/32	0.7813
7/64	0.1094	29/54	0.5370	51/64	0.7969
1/8	0.1250	15/32	0.4688	13/16	0.8125
9/64	0.1406	31/64	0.4844	53/64	0.8281
5/32	0.1562	1/2	0.5000	27/32	0.8438
11/64	0.1719	11/18	0.6111	55/64	0.8594
3/16	0.1875	17/32	0.5313	7/8	0.8750
13/64	0.2031	35/64	0.5469	57/64	0.8906
7/32	0.2187	3/8	0.3750	29/32	0.9063
15/64	0.2344	37/64	0.5781	59/64	0.9219
1/4	0.2500	19/32	0.5938	15/16	0.9375
17/64	0.2656	39/64	0.6094	61/64	0.9531
9/32	0.2812	5/8	0.6250	31/32	0.9688
19/64	0.2969	41/64	0.6406	63/64	0.9844
5/16	0.3125	21/32	0.6563	1	1.0000
21/64	0.3281	43/64	0.6719		
11/32	0.3438	11/16	0.6875		

Decimal Equivalents of standard gauge sheet aluminum and sheet steel								
No. of Gauge	Gauge		No. of Gauge	Gauge		No. of Gauge	Gauge	
	Aluminum (B & S)	Steel (U.S. Std.)		Aluminum (B & S)	Steel (U.S. Std.)		Aluminum (B & S)	Steel (U.S. Std.)
10	0.1019	0.1345	17	0.0453	0.0538	24	0.0201	0.0239
11	0.0907	0.1196	18	0.0403	0.0478	25	0.0179	0.0209
12	0.0808	0.1046	19	0.0359	0.0418	26	0.0159	0.0179
13	0.0720	0.0897	20	0.0320	0.0359	27	0.0142	0.0164
14	0.0641	0.0747	21	0.0285	0.0329	28	0.0126	0.0149
15	0.0571	0.0673	22	0.0253	0.0299	29	0.0113	0.0135
16	0.0508	0.0598	23	0.0226	0.0269	30	0.0100	0.0120

About us.

Joining together! – our company vision.
A vision that inspires our company culture and daily life.

This inspiration drives our product program in the world of fastening and assembly technology. “Joining together” is much more than just a neat slogan. It is also a business vision that puts people first. Because it is people who put the vision into practice and build the solid foundation of our success today and in the future.

For four generations, courage, fairness and loyalty have been the cornerstones of our business culture. The foundation on which we have built success for our company, our customers, our business partners and our employees.

Böllhoff. Joining together!



Wilhelm Alexander Böllhoff

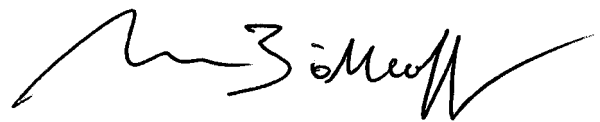

Michael Wolfgang Böllhoff



Wilhelm A. Böllhoff Michael W. Böllhoff
Managing Partners, Böllhoff Group

Steven P. Paddock
President, North America

Böllhoff International with companies in:



Argentina
Austria
Brazil
Canada
China
Czech Republic
France
Germany
Hungary
India
Italy
Japan
Mexico
Poland
Romania
Russia
Slovakia
Spain
Turkey
United Kingdom
USA

Apart from these 21 countries, Böllhoff supports its international customers in other important industrial markets in close partnership with agents and dealers.

Authorized Distributor



(877)923-2900

B'OLLHOFF

Fastening & Assembly Technology

2705 Marion Drive
Kendallville, IN 46755
ph: 260.347.3903
fax: 260.347.9429
www.bollhoff-rivnut.com

Issue Date: October 2010

©Copyright Böllhoff Inc., October, 2010

RIVNUT®, PLUSNUT®, RIVSTUD®, RIVKLE® and UNILOCK® are registered trademarks of Böllhoff Inc., USA

